

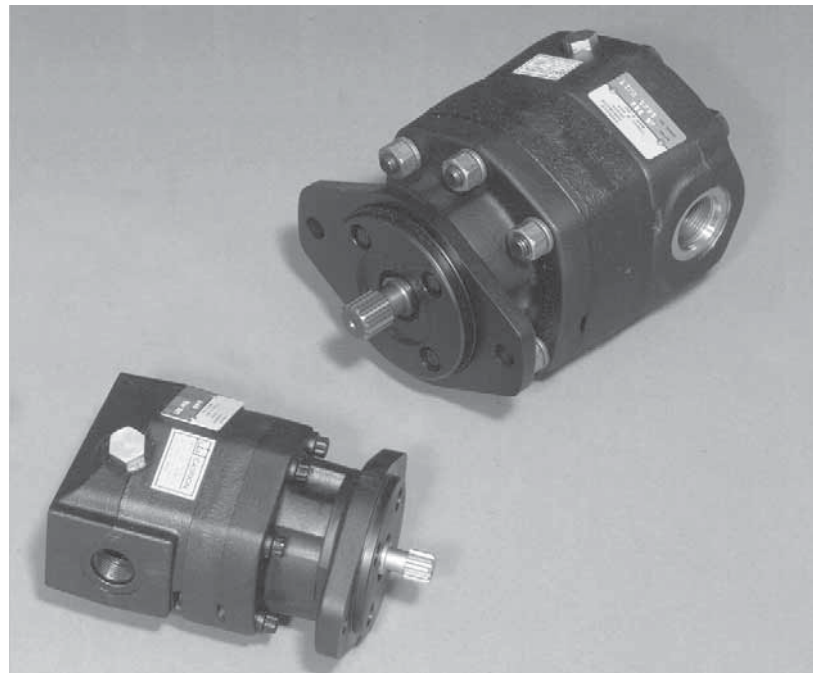

# *High Speed Hydraulic Motors*

*Catalog HY13-2600-800-001/NA*

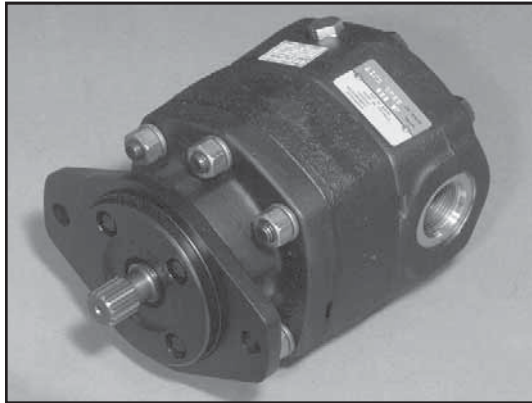



## Features

- **High Starting Torque** typically 90% of running torque.
- **Smooth Output Torque** throughout the entire speed range of the motor.
- **High Speed Capabilities** up to 7500 rpm on some models.
- **Bi-Directional Operation** built in checks internally relieve high pressure from the shaft seal.
- **High Pressure Shaft Seal** allows back pressure to 400 PSI without the requirement of Case Drain.
- **Standard SAE Mounting** 2 or 4 bolt mounting flanges, shaft and port dimensions conform to SAE standards.
- **Long Life & Quiet Operation** Precision Gerotor Design results in a motor with extended operating life and noise levels below most other hydraulic motors.
- **Heavy Duty Bearings** capable of withstanding radial and thrust loads.

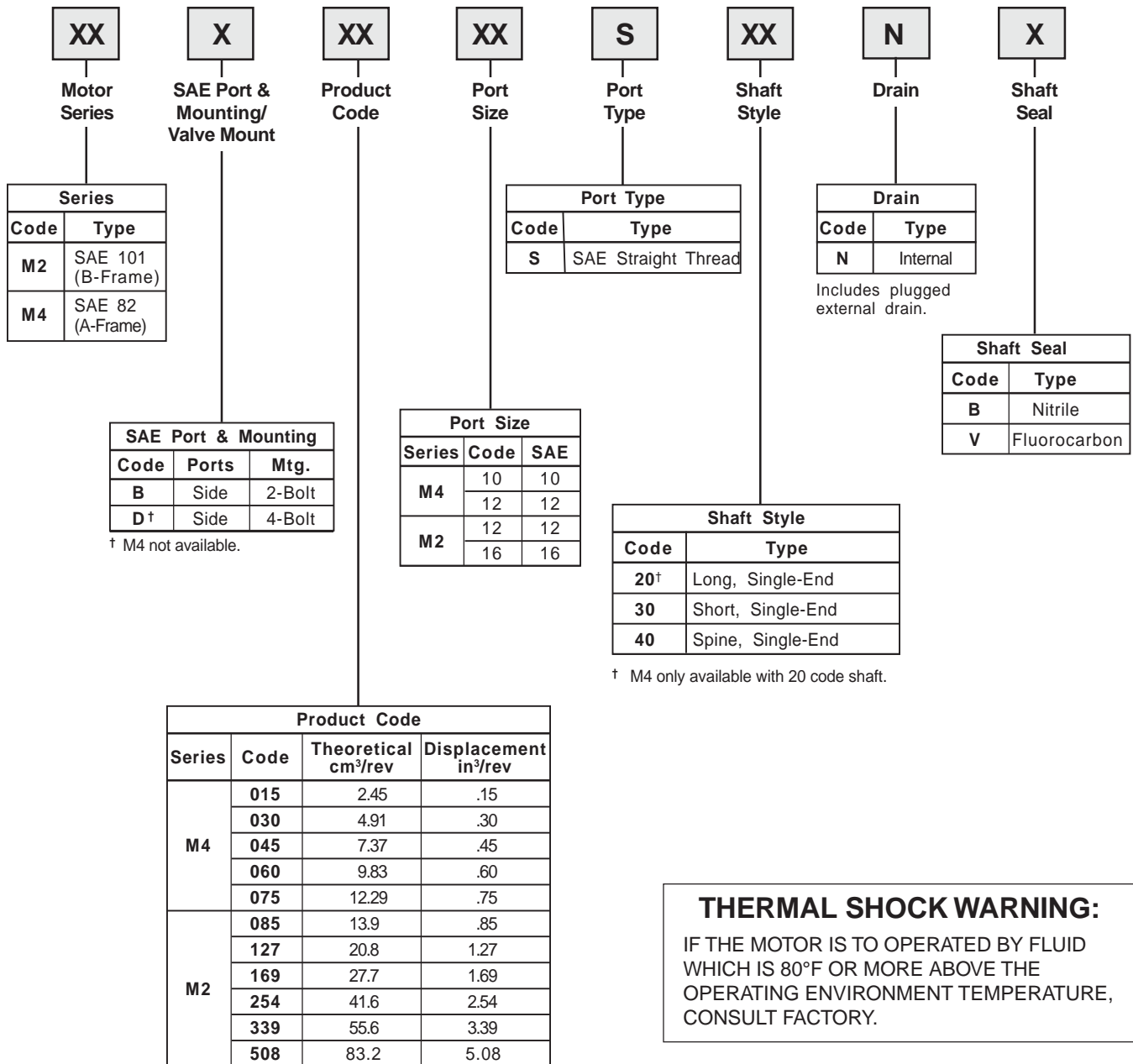

**THERMAL SHOCK WARNING:**  
IF THE MOTOR IS TO OPERATED BY FLUID WHICH IS 80°F OR MORE ABOVE THE OPERATING ENVIRONMENT TEMPERATURE, CONSULT FACTORY.

## Applications

Parker motors serve our customers worldwide in many industries and in many applications. Typical applications include:

- Fan Drives** High speed capabilities means increased cooling capacity. Rugged bearing design allows the fan to be mounted directly on the motor shaft.
- Swing Drives** High starting torque and smooth output torque throughout the motor's speed range means optimum control.
- Vibratory Drives** Rugged design, high speed capabilities, and optional cross port relief valve means maximum life for vibratory drives.
- Wheel Drives** High speed capabilities and high starting torque means faster road speeds and increased productivity.
- Winch Drives** Smooth output torque throughout the speed range, high speed capabilities, and high starting torque means increased control, greater productivity.

### Starting and running torque comparison between Parker Gerotor and typical Spur Gear and Vane Motors.

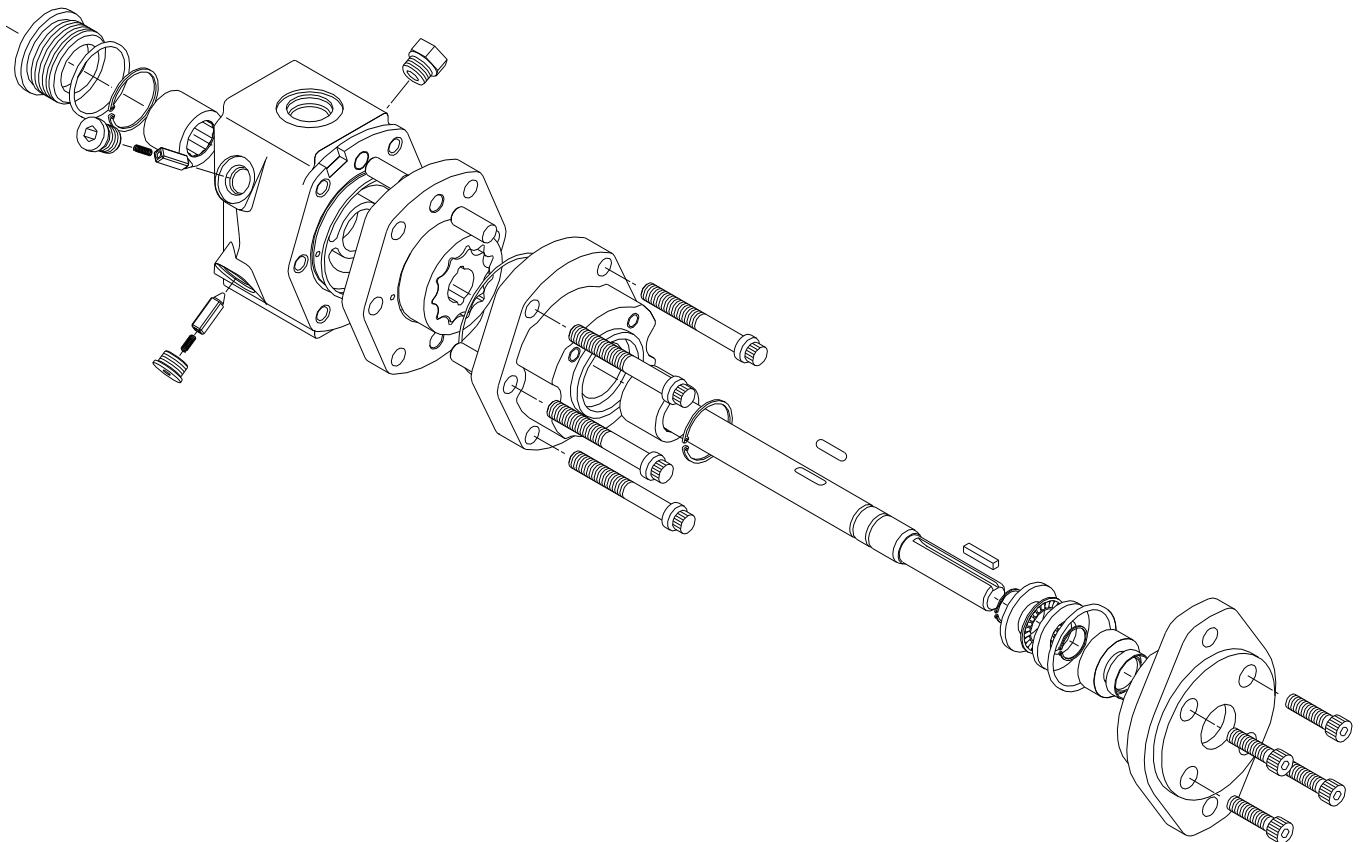
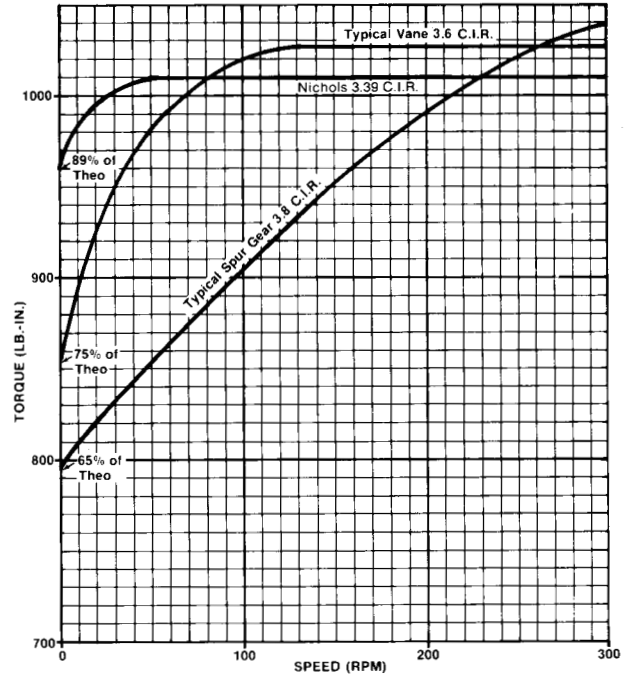

Performance Data & Mounting Data

M4-015

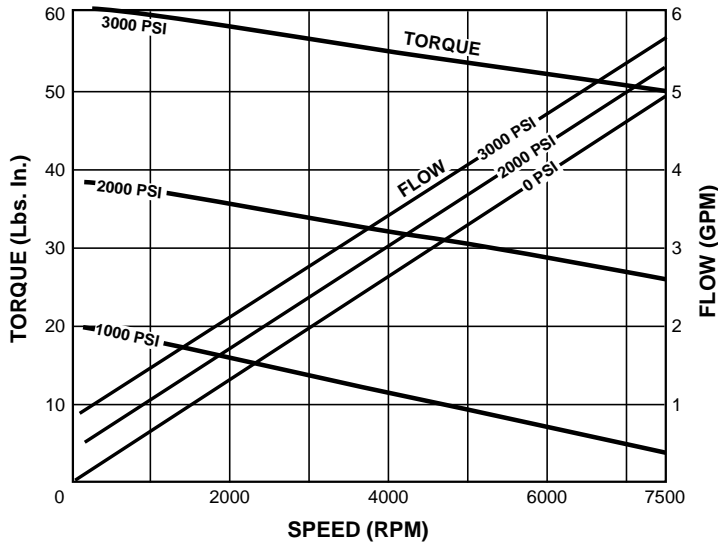

M4-030

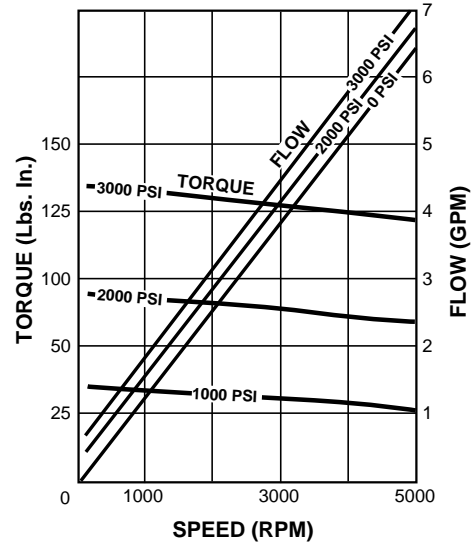

M4-060

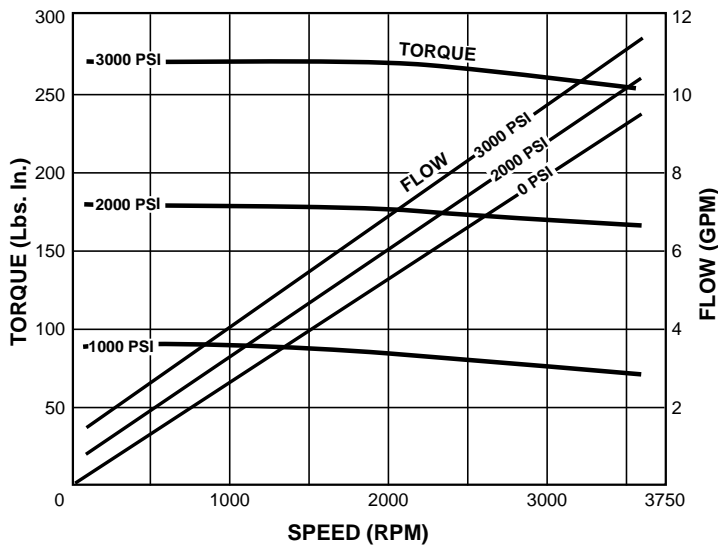

M4-075

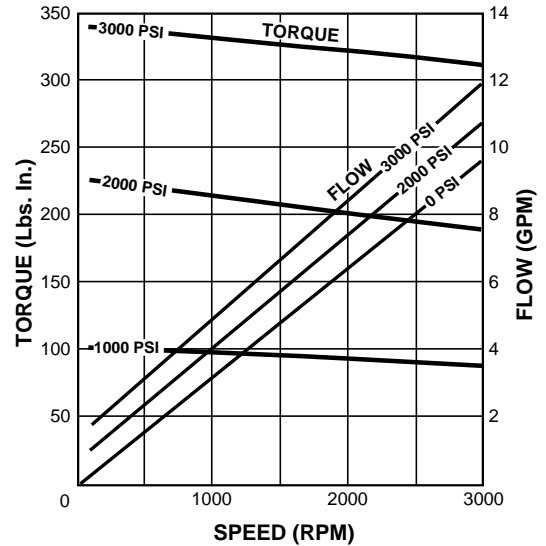

Displacement

	cm <sup>3</sup> /rev	(in <sup>3</sup> /rev)
015 Unit	2.45	(.15)
030 Unit	4.91	(.30)
045 Unit	7.37	(.45)
060 Unit	9.83	(.60)
075 Unit	12.29	(.75)

Speed

	Recommended Range
015 Unit	75 to 7500 rpm
030 Unit	50 to 5000 rpm
045 Unit	50 to 5000 rpm
060 Unit	36 to 3600 rpm
075 Unit	30 to 3000 rpm

Performance Curves:

Data based on:  
Oil: 65 cst (300 SSU)  
Mobil DTE-26  
Temp: 38°C (100°F)

Weight

	Kg	(lb)
015 Unit	7.3	(16)
030 Unit	7.7	(17)
045 Unit	8.2	(18)
060 Unit	8.6	(19)
075 Unit	9.1	(20)

Minimum speeds indicated are based on constant load. For speeds outside of the recommended range, consult the factory.

Pressure

Continuous: 2000 PSI  
† Intermittent, Max: 2400 PSI  
‡ Transient, Max: 3000 PSI

† Intermittent conditions are to be less than 10% of each minute.  
‡ Transient conditions are to be less than 1% of every minute.

Performance Data & Mounting Data

M4-045

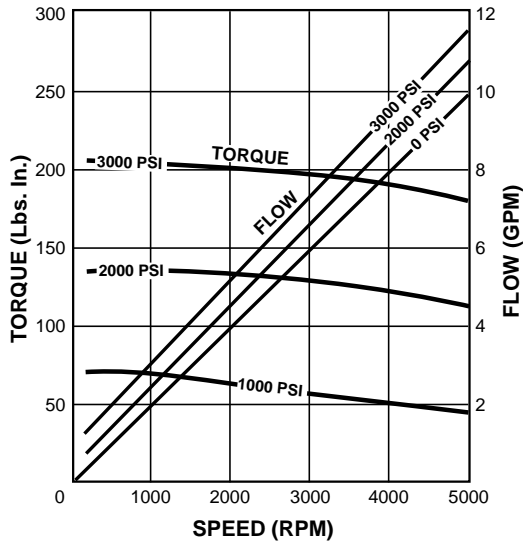

Dimensions are shown in millimeters.  
Dimensions within ( ) are in inches.

Code	A	B
015	143.26 (5.64)	107.44 (4.23)
030	149.61 (5.89)	113.79 (4.48)
045	156.21 (6.15)	120.14 (4.73)
060	162.31 (6.39)	126.49 (4.98)
075	168.66 (6.64)	132.84 (5.23)

MOUNTING DATA

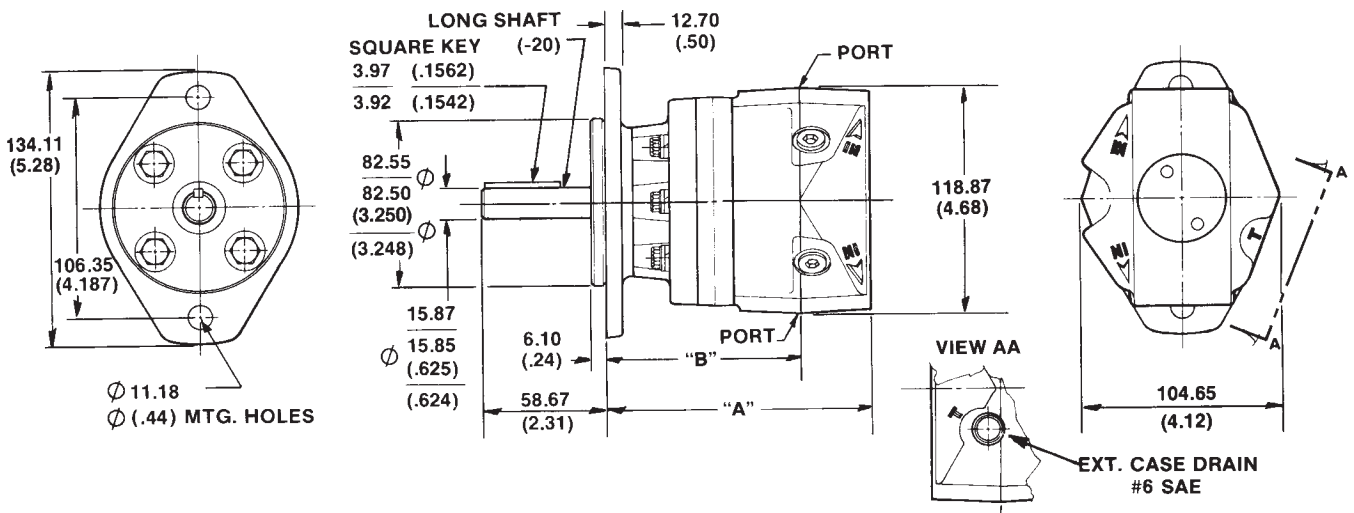

Performance Data

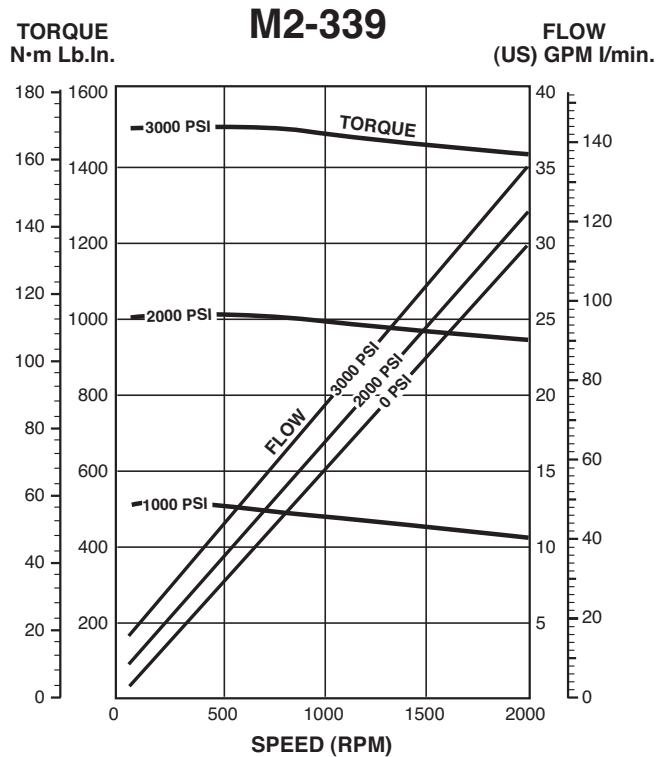
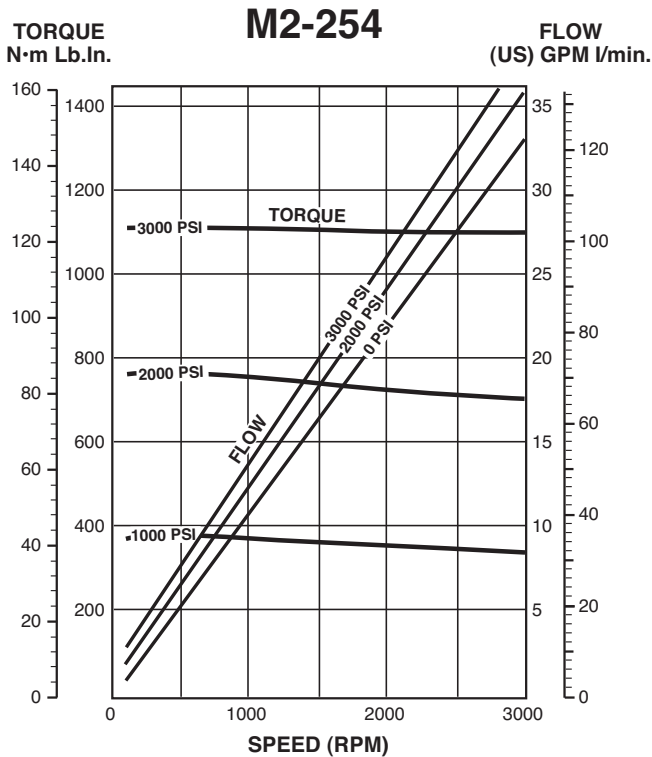
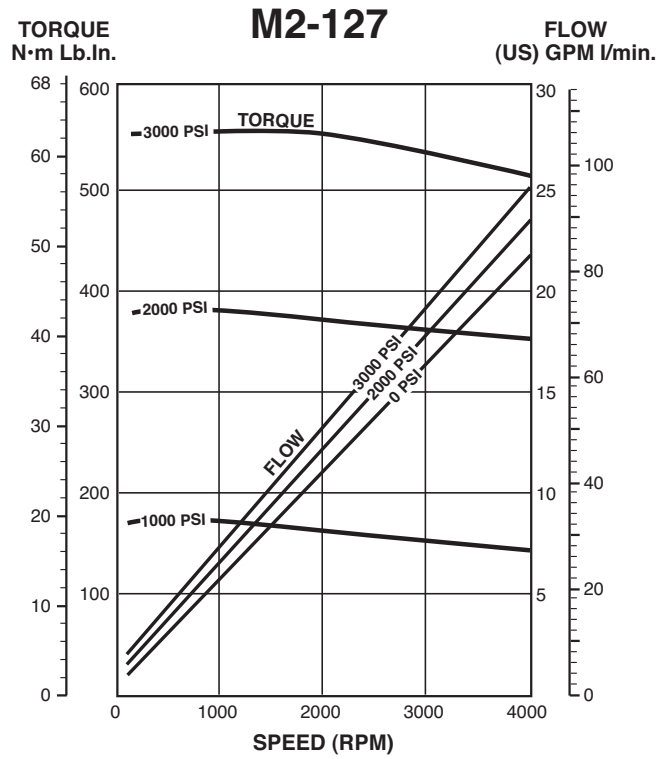
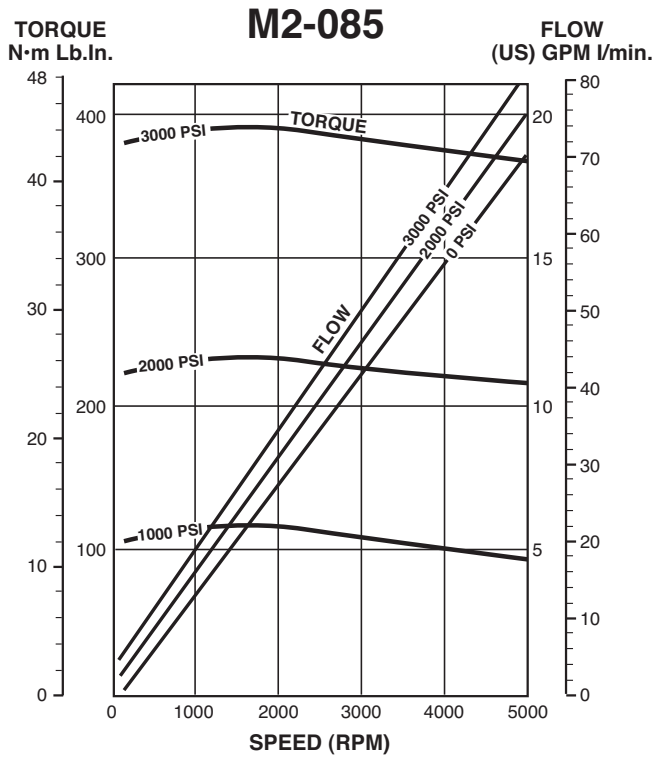

Performance Data

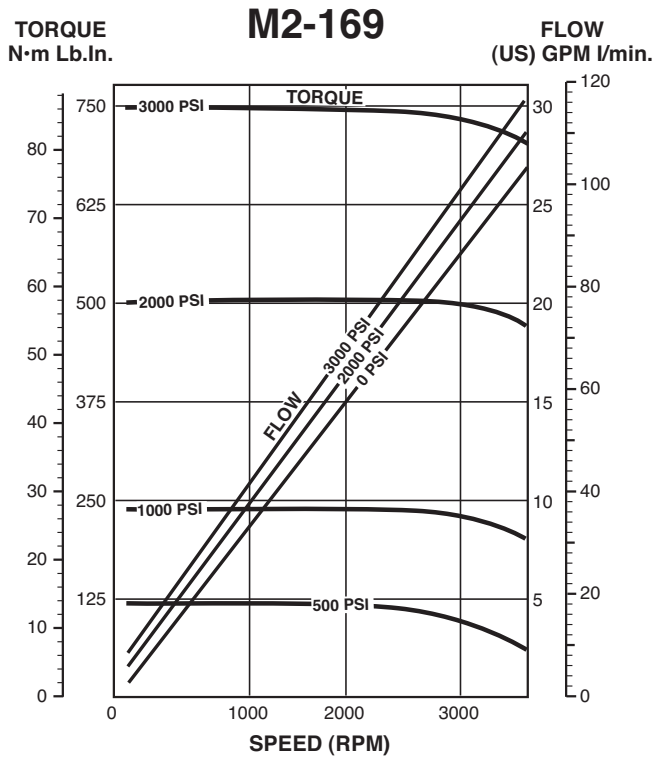

Displacement

	cm <sup>3</sup> /rev	(in <sup>3</sup> /rev)
085 Unit	13.9	(0.85)
127 Unit	20.8	(1.27)
169 Unit	27.7	(1.69)
254 Unit	41.6	(2.54)
339 Unit	55.6	(3.39)
508 Unit	83.2	(5.08)

Pressure

- Continuous:  
 M2-508 1000 PSI  
 All other Units 2000 PSI
- † Intermittent, Max:  
 M2-508 1400 PSI  
 All other Units 2400 PSI
- ‡ Transient, Max:  
 M2-508 1700 PSI  
 All other Units 3000 PSI

† Intermittent conditions are to be less than 10% of each minute.  
 ‡ Transient conditions are to be less than 1% of every minute.

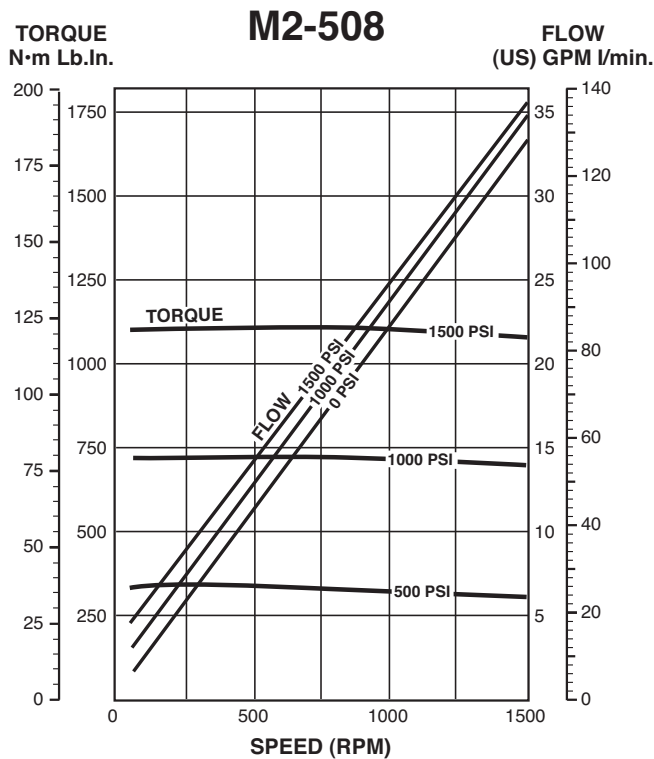

Speed

Recommended Range

085 Unit	50 to 5000 rpm
127 Unit	40 to 4000 rpm
169 Unit	36 to 3600 rpm
254 Unit	30 to 3000 rpm
339 Unit	20 to 2000 rpm
508 Unit	15 to 1500 rpm

Minimum speeds indicated are based on constant load.  
 For speeds outside of the recommended range, consult the factory.

Weight

085 Unit	15.4 Kg	(34 lb)
127 Unit	16.3 Kg	(36 lb)
169 Unit	17.2 Kg	(38 lb)
254 Unit	18.6 Kg	(41 lb)
339 Unit	20.4 Kg	(45 lb)
508 Unit	24.0 Kg	(52 lb)

Performance Curves:

Data based on:  
 Oil: 65 cst (300 SSU) Mobil DTE-26  
 Temp: 38°C (100°F)

\* Stall torque band is application dependent, consult factory.



### Mounting Data

Dimensions are shown in millimeters.  
Dimensions within ( ) are in inches.

Code	Dimension "A"
085	158.8 (6.25)
127	165.1 (6.50)
169	171.5 (6.75)
254	184.2 (7.25)
339	196.9 (7.75)
508	222.3 (8.75)

### FLANGE OPTION SAE 101-4 Mounting

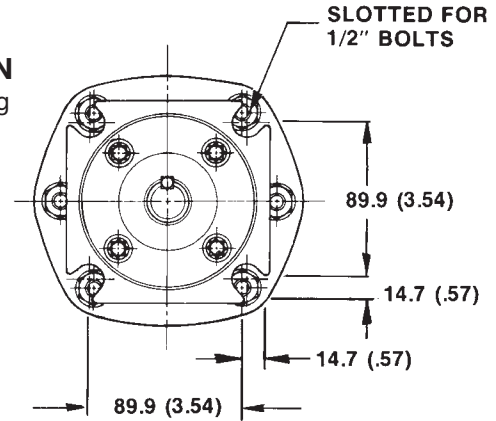

### DIMENSIONS

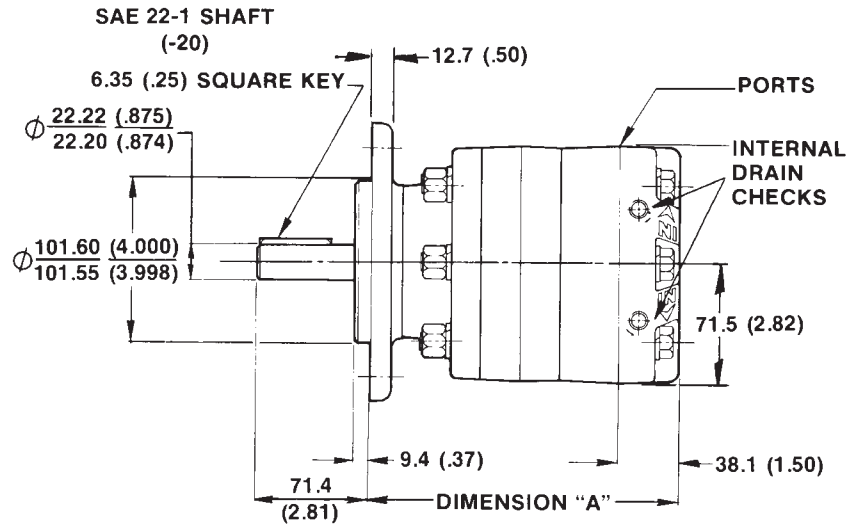
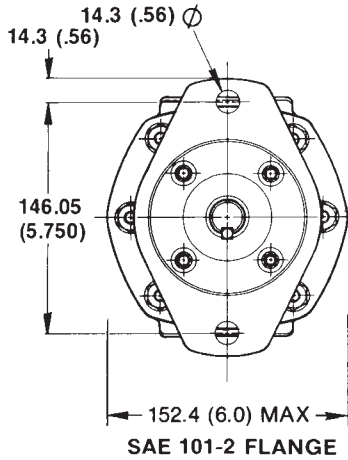

### PORT LOCATION

1. The shaft will rotate in the direction of this "ARROWHEAD" when Port "A" is the inlet "IN" or pressure port.
2. With Port "B" as the inlet "IN" or pressure port, the shaft will rotate in the direction of this "ARROWHEAD".

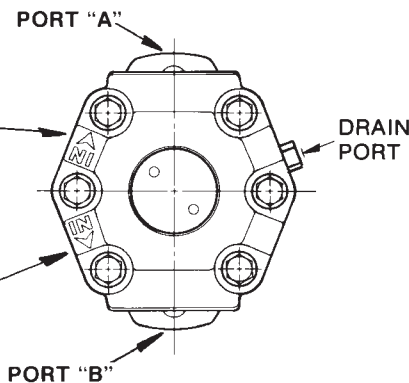

### DRAIN PORT

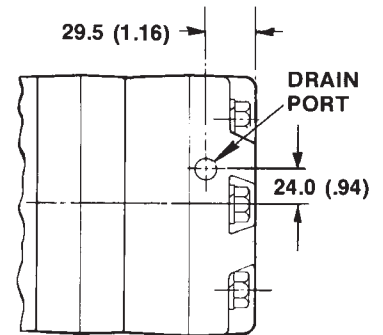

Drain Port Will Be:

1. No. 6-SAE for the SAE ported motors.

## Mounting Data

### SHAFT OPTIONS

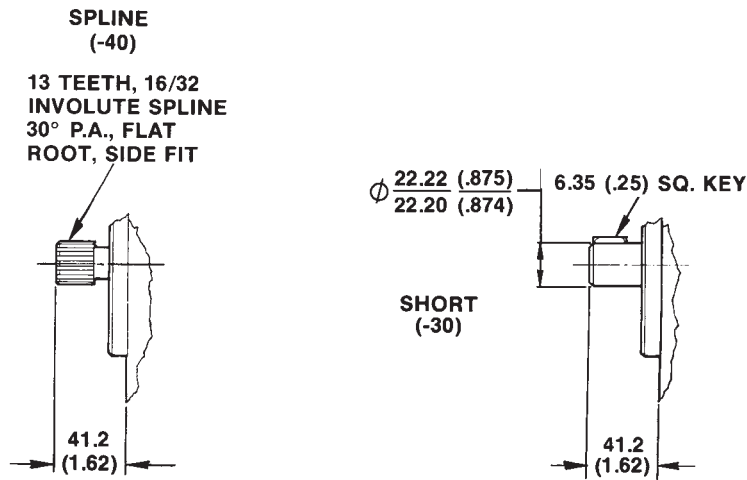

**Operating Pressures**

Continuous:

M2-508 1000 PSI

All other Units 2000 PSI

Intermittent, Max:

M2-508 1400 PSI

All other Units 2400 PSI

Transient, Max:

M2-508 1700 PSI

All other Units 3000 PSI

**Filtration**

25 micron or less

**Fluids**

To insure ultimate component life, use premium quality hydraulic oils. Fluids with effective quantities of anti-wear agents or additives, (such as Mobil Oil DTE-26), are highly recommended.

**Viscosity**

Maximum 1000 centistokes  
5000 SSU

Minimum 13.5 centistokes  
70 SSU

**Recommended Temperature Range**

-40°C (-40°F) to 82°C (180°F)

**Case Drain Precaution**

If outlet port exceeds 400 PSI, the external case drain should be used with no more than 400 PSI back pressure.

**Dimensions**

Published dimensions are nominal. Allowances should be made for dimensional variations of cast parts.

**Installation Requirements**

Pulleys, sprockets, and belts should be properly aligned on the shaft; and fan blades should be properly sized to prevent excessive thrust loads.

**Shaft Seal**

The standard Nitrile shaft seal is adequate for most applications. For applications which involve shaft speeds above 2500 rpm or synthetic fluids, the operational Viton shaft seal should be specified.

**Static Seals**

All the o-rings included within the motor and the shaft dust seal are Nitrile. They may be used with all types of hydraulic fluids. However, since these seals swell after exposure to ester base synthetic fluids, they should be replaced if the motor is repaired.

**Motor Precaution**

A hydraulic motor is not designed to hold a suspended load. Therefore, if the application requires a locked position, a mechanical holding device (such as a brake) must be employed. Consult factory for availability.

**For different operating conditions, consult the factory.**

