

EIPH2  
EIPH3  
EIPH5  
EIPH6

Internal gear pumps

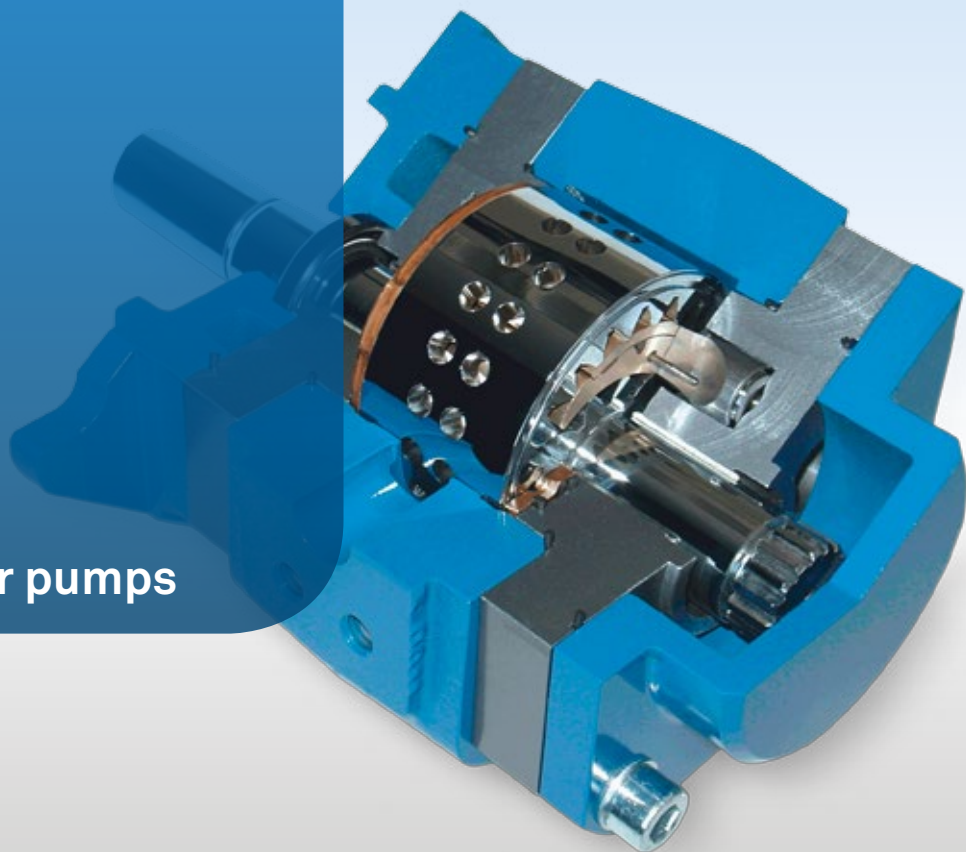

# Internal gear pump

## Type EIPH2 high pressure pump with constant displacement volume

EIPH2

### Characteristics

- Internal gear pump with axial and radial gap compensation
- Radial compensation with segments
- Suction and pressure port radial
- Field of application: Industrial hydraulic
- Low noise
- Long time life
- Low pulsation (pressure pulsation ~2 %)
- Multi flow combinations

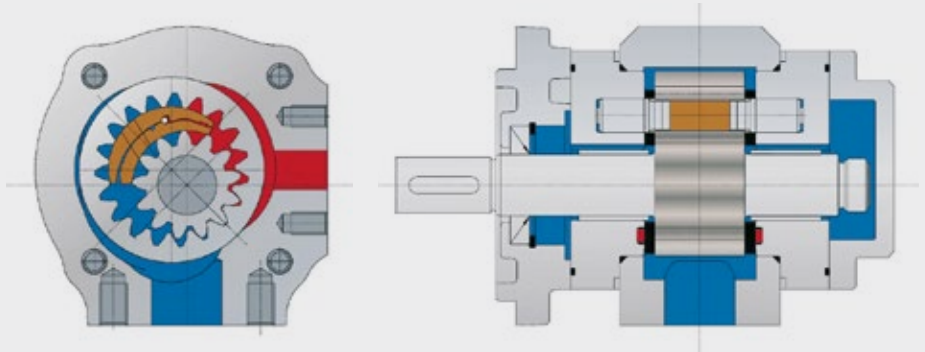

### Technical Data:

Rated Size	004	005	006	008	011	013	016	019	022	025
Spec. volume Vth [cm <sup>3</sup> /rev]***	4,2	5,4	6,4	7,9	10,9	13,3	15,8	19,3	22,2	25,2
Continuous operating pressure [bar]**				330			300			250
Peak operating pressure [bar] max. 10 sec. 15% duty cycle**				350			300			280
Cut-in pressure peak [bar]**				400			325			300
Nominal speed [min <sup>-1</sup> ]	400 – 3.600			400 – 3.400	400 – 3.200		400 – 3.000	400 – 2.500		400 – 2.300
Max. speed [min <sup>-1</sup> ]	4.200			4.000			3.000			
Nominal speed [min <sup>-1</sup> ]****							400 – 3.000		400 – 2.800	
Max. speed [min <sup>-1</sup> ]****							3.600			
Operating viscosity [mm <sup>2</sup> /s]				10 – 300						
Starting viscosity [mm <sup>2</sup> /s]				2.000						
Operating medium				HL – HLP DIN 51 524 Teil 1/2						
Max. medium temperature [°C]				80						
Min. medium temperature [°C]				-20						
Max. ambient temperature [°C]				80						
Min. ambient temperature [°C]				-20						
Max. admission pressure (intake side) [bar]				2 bar absolute						
Min. admission pressure (intake side) [bar]				0,8 bar absolute (Start 0,6)						
Weight appr. [kg]	4,9	5,0	5,2	5,4	5,5	5,7	7,4	7,8	8	
Degree of filtration				Class 20/18/15 due to ISO 4406						
Life expectancy				not less than 1x 10 <sup>7</sup> load cycles against peak operating pressure						
Efficiency $\eta$ vol:	88	91	92	93		94	95			
Efficiency $\eta$ hm:	85	90		91	92		93			
Pump noise* (measured in sound chamber) dB[A]	53	54	55	57	58	59	60	61	62	63

n = 1.450 min<sup>-1</sup>     $\Delta p$  = 250 bar    T = 50 °C    Medium: HLP 46

\* Measured in anechoic room of Eckerle Hydraulic Division; Axial microphone distance 1.0 m

\*\* For acceptable pressure at 400-1.800 rpm. Further rpm on request.

\*\*\* Due to manufacturing tolerances the displacement volume could vary.

\*\*\*\* 1 1/2" suction port

The pumps have no corrosion protection.

The max. permissible values must not be applied cumulatively. Please contact us.

# Internal gear pump

## Type EIPH3 high pressure pump

### with constant displacement volume

EIPH3

#### Characteristics

The series EIPH were developed particularly for the high requirements of industrial hydraulics. Their favourable noise characteristic, extremely low delivery and pressure pulsation, outstanding efficiency within broad revolution and viscosity ranges, have firmly established gap-compensated high pressure internal gear pumps among high pressure pumps. Simple combinability to multiple pumps with separate or common inlet is given.

The EIPH is a consistent advancement that already for over 40 years in the industry used gap-compensated internal gear pump technology, System Eckerle.

#### Technical Data:

Rated Size	014	016	020	025	032	040	050	064	
Spec. volume Vth [cm <sup>3</sup> /rev]***	14,6	16,0	20,0	24,8	32,1	40,1	50,3	64,6	
Continuous operating pressure [bar]**	330						280		
Peak operating pressure [bar] max. 10 sec. 15% duty cycle**	350						300		
Cut-in pressure peak [bar]**	400						325		
Nominal speed [min <sup>-1</sup> ]	400 – 3.600		400 – 3.400	400 – 3.200	400 – 3.000	400 – 3.000	400 – 1.800		
Max. speed [min <sup>-1</sup> ]	4.000		3.400	3.200	3.000	2.500	1.800		
Nominal speed [min <sup>-1</sup> ]****							400 – 3.200	400 – 3.000	400 – 2.200
Max. speed [min <sup>-1</sup> ]****							3.600		2.500
Operating viscosity [mm <sup>2</sup> /s]	10 – 300								
Starting viscosity [mm <sup>2</sup> /s]	2.000								
Operating medium	HL – HLP DIN 51 524 Teil 1/2								
Max. medium temperature [°C]	80								
Min. medium temperature [°C]	-20								
Max. ambient temperature [°C]	80								
Min. ambient temperature [°C]	-20								
Max. admission pressure (intake side) [bar]	2 bar absolute								
Min. admission pressure (intake side) [bar]	0,8 bar absolute (Start 0,6)								
Weight appr. [kg]	9,4	10,1	10,5	11,2	12,0	15	17	18	
Degree of filtration	Class 20/18/15 due to ISO 4406								
Life expectancy	not less than 1x 10 <sup>7</sup> load cycles against peak operating pressure								
Efficiency η vol:	91	92	93		94	95			
Efficiency η hm:	90		91	92		93			
Pump noise* (measured in sound chamber) dB[A]	60	61	62	63	64	65	66		

n = 1.450 min<sup>-1</sup>    Δ p = 250 bar    T = 50 °C    Medium: HLP 46

\* Measured in anechoic room of Eckerle Hydraulic Division; Axial microphone distance 1.0 m

\*\* For acceptable pressure at 400-1.800 rpm. Further rpm on request.

\*\*\* Due to manufacturing tolerances the displacement volume could vary.

\*\*\*\* 2" suction port

The pumps have no corrosion protection.

The max. permissible values must not be applied cumulatively. Please contact us.

# Internal gear pump

## Type EIPH5 high pressure pump with constant displacement volume

EIPH5

### Technical Data:

Rated Size	064	080	100
Spec. volume V <sub>th</sub> [cm <sup>3</sup> /rev]**	65,3	80,4	100,5
Continuous operating pressure [bar]**	280		
Peak operating pressure [bar] max. 10sec 15% duty cycle**	290		
Cut-in pressure peak [bar]**	300		
Nominal speed [rpm]	100 – 2.800		100 – 2.500
Max. speed [rpm]	3.000		
Operating viscosity [mm <sup>2</sup> /s]	10 – 300		
Starting viscosity [mm <sup>2</sup> /s]	2.000		
Operating medium	HL – HLP DIN 51 524 Teil 1/2		
Max. medium temperature [°C]	80		
Min. medium temperatur [°C]	-20		
Max. ambient temperature [°C]	80		
Min. ambient temperature [°C]	-20		
Max. admission pressure (intake side) [bar]	2 bar absolute		
Min. admission pressure (intake side) [bar]	0,8 bar absolute (Start 0,6)		
Weight appr. [kg]:	15,3	17,5	18,7
Degree of filtration	Class 20/18/15 due to ISO 4406		
Life expectancy	not less than 1x 10 <sup>7</sup> load cycles against peak operating pressure		
Efficiency $\eta$ vol:	94	95	95
Efficiency $\eta$ hm:	92	93	93
Pump noise* (measured in sound chamber) dB[A]	69	70	71

n = 1.450 min<sup>-1</sup>     $\Delta p$  = 250 bar    T = 50 °C    Medium: HLP 46

\* Measured in anechoic room of Eckerle Hydraulic Division; Axial microphone distance 1.0 m

\*\* For acceptable pressure at 400-1.800 rpm. Further rpm on request.

\*\*\* Due to manufacturing tolerances the displacement volume could vary.

\*\*\*\* 1 ½" suction port.

The pumps have no corrosion protection.  
The max. permissible values must not be applied cumulatively. Please contact us.

# Internal gear pump

## Type EIPH6 high pressure pump with constant displacement volume

EIPH6

### Technical Data:

Rated Size	040	050	064	080	100	125	160	200	250
Spec. volume V <sub>th</sub> [cm <sup>3</sup> /rev]***	40,8	50,6	65,3	80,0	101,2	125,7	160,1	200,9	249,9
Continuous operating pressure [bar]**	330		315	300		250		160	140
Peak operating pressure [bar] max. 10sec 15% duty cycle**	340		330		280		170	150	
Cut-in pressure peak [bar]**	350		340		300		180	160	
Nominal speed [rpm]	400 – 2.200			400 – 2.000			400 – 1.800		
Max. speed [rpm]	2.400			2.200			2.000		
Operating viscosity [mm <sup>2</sup> /s]	10 – 300								
Starting viscosity [mm <sup>2</sup> /s]	2.000								
Operating medium	HL – HLP DIN 51 524 Teil 1/2								
Max. medium temperature [°C]	80								
Min. medium temperatur [°C]	-20								
Max. ambient temperature [°C]	80								
Min. ambient temperature [°C]	-20								
Max. admission pressure (intake side) [bar]	2 bar absolute								
Min. admission pressure (intake side) [bar]	0,8 bar absolute (Start 0,6)								
Weight appr. [kg]:	31	32	34	36	39	42	46	51	58
Degree of filtration	Class 20/18/15 due to ISO 4406								
Life expectancy	not less than 1x 10 <sup>7</sup> load cycles against peak operating pressure								
Efficiency η vol:	93		94		95		96		
Efficiency η hm:	89		90		91		92		
Pump noise* (measured in sound chamber) dB[A]	72	73	74	75	76	77	78	79	80

n = 1.450 min<sup>-1</sup>    Δ p = 250 bar    T = 50 °C    Medium: HLP 46

\* Measured in anechoic room of Eckerle Hydraulic Division; Axial microphone distance 1.0 m

\*\* For acceptable pressure at 400-1.800 rpm. Further rpm on request.

\*\*\* Due to manufacturing tolerances the displacement volume could vary.

\*\*\*\* 1 ½" suction port.

The pumps have no corrosion protection.

The max. permissible values must not be applied cumulatively. Please contact us.

## Pump with SAE-A-2-hole flange and cylindrical shaft

Order example: EIPH2-\_\_\_RK03-1X

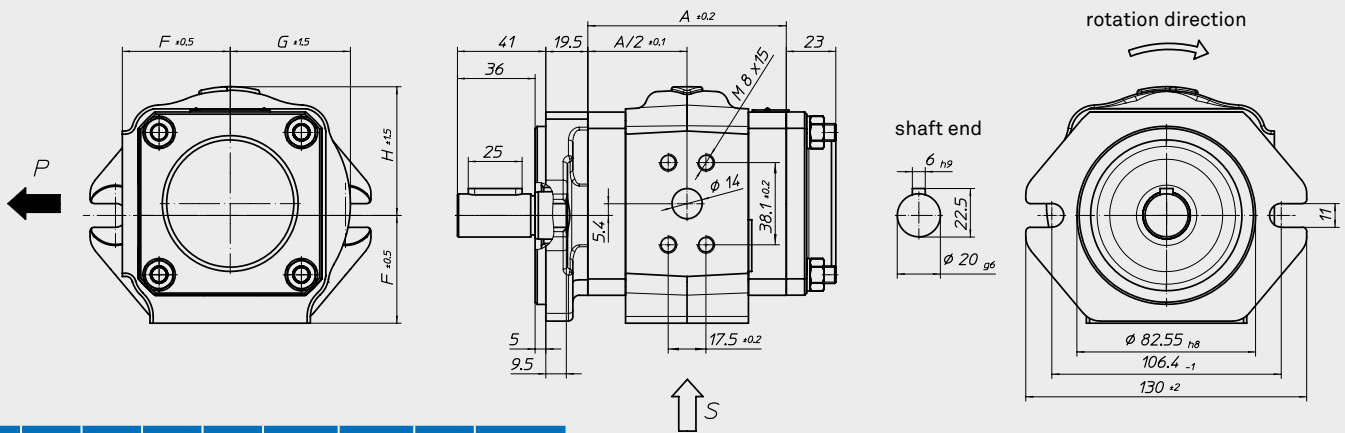

Size	A	F	G	H	L	M	N	O
004	71	50	55	59	38,1	17,5	14	M8x15
005	71	50	55	59	38,1	17,5	14	M8x15
006	73	50	55	59	47,5	22	19	M10x16
008	76	50	55	59	47,5	22	19	M10x17
011	82	50	55	59	52,4	26,2	25	M10x17
013	87	50	55	60	52,4	26,2	25	M10x17
016	92	50	55	60	52,4	26,2	25	M10x17
019	99	55	61	65	52,4	26,2	25	M10x17
022	105	55	61	65	52,4	26,2	25	M10x17
025	111	55	61	65	52,4	26,2	25	M10x17

suction port

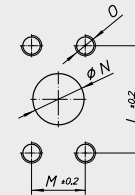

enlarged suction port\*

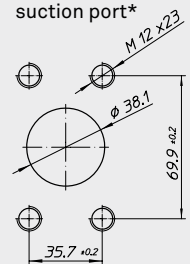

\* is suitable for speed controlled drive applications (available only for sizes 019, 022, 025)

## Double pump with SAE-A-2-hole flange and cylindrical shaft

Order example: EIPH2-\_\_\_RK00-1X+  
EIPH2-\_\_\_RP30-1X

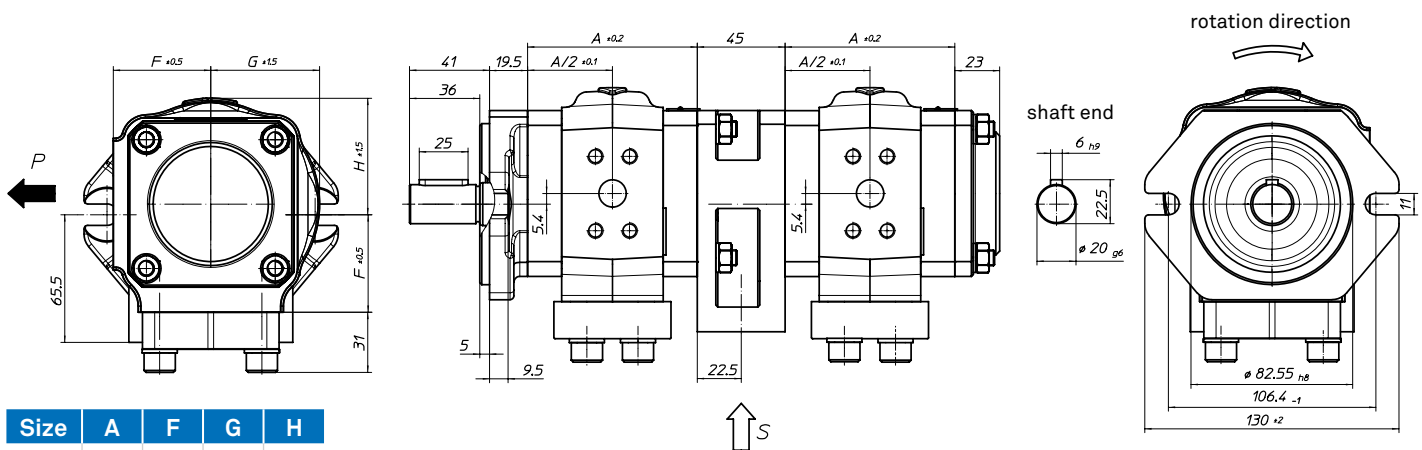

Size	A	F	G	H
004	71	50	55	59
005	71	50	55	59
006	73	50	55	59
008	76	50	55	59
011	82	50	55	59
013	87	50	55	60
016	92	50	55	60
019	99	55	61	65
022	105	55	61	65
025	111	55	61	65

Pressure connections see single pumps

suction port

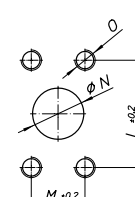

enlarged suction port\*

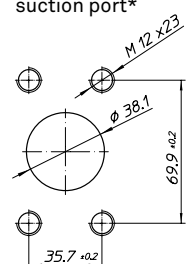

\* is suitable for speed controlled drive applications (available only for sizes 019, 022, 025)

# Dimensions

# EIPH3

## Pump with SAE-B-2-hole flange and cylindrical shaft

Order example: EIPH3-\_\_\_RK23-1X

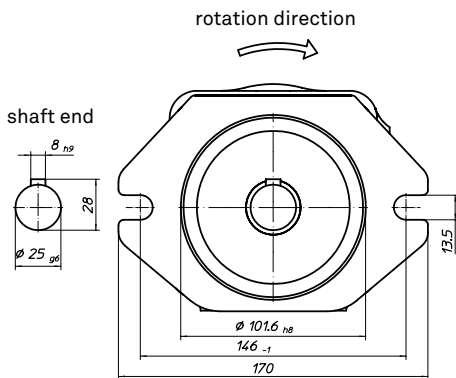
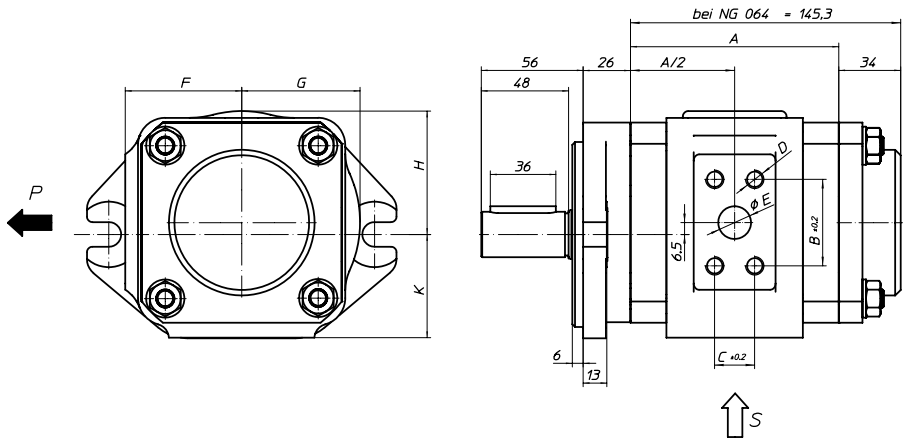

Size	A	B	C	D	E	F	G	H	K	L	M	N	O
014	90,4	38,1	17,5	M8x15	14	64	65	67	57	52,4	26,2	25	M10x17
016	92,4	38,1	17,5	M8x15	14	64	65	67	57	52,4	26,2	25	M10x17
020	97,9	47,5	22	M10x17	18	64	65	67	57	58,7	30,2	32	M10x17
025	104,4	47,5	22	M10x17	18	64	65	67	57	58,7	30,2	32	M10x17
032	114,4	47,5	22	M10x17	18	64	65	67	57	58,7	30,2	32	M10x17
040	125,4	52,4	26,2	M10x17	20	70	73	79	63	58,7	30,2	32	M10x20
050	139,4	52,4	26,2	M10x17	20	70	73	79	63	58,7	30,2	32	M10x20
064		52,4	26,2	M10x17	20	70	73	79	63	58,7	30,2	32	M10x20

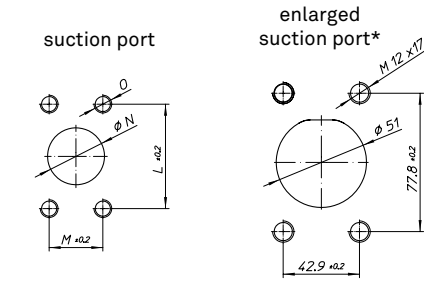

\* is suitable for speed controlled drive applications (available only for sizes 040, 050, 064)

## Double pump with SAE-B-2-hole flange and cylindrical shaft

Order example: EIPH3-\_\_\_RK20-1X+  
EIPH3-\_\_\_RP30-1X

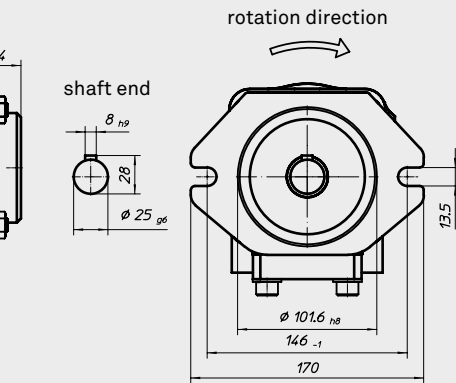
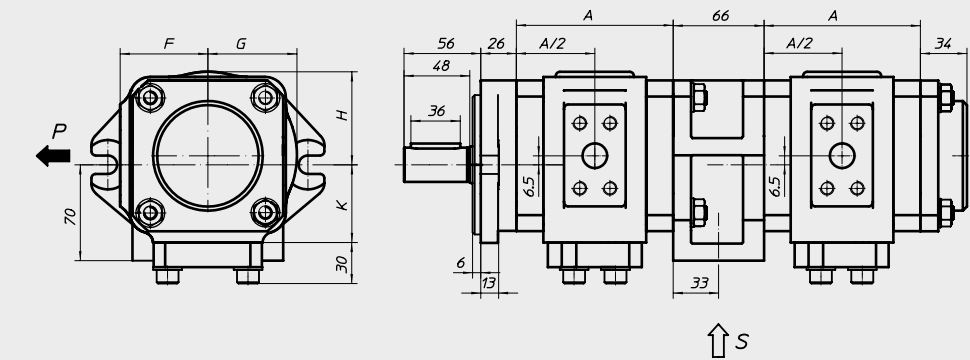

Size	A	F	G	H	K
014	90,4	64	65	67	57
016	92,4	64	65	67	57
020	97,9	64	65	67	57
025	104,4	64	65	67	57
032	114,4	64	65	67	57
040	125,4	70	73	79	63
050	139,4	70	73	79	63

common suction port

size 014-032

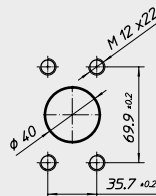

size 040-050

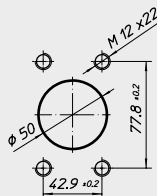

Pressure connections see single pump

# Dimensions

# EIPH3/2

## Double pump with SAE-B-2-hole flange and cylindrical shaft

Order example: EIPH3-\_\_\_RK20-1X+  
EIPH2-\_\_\_RP30-1X

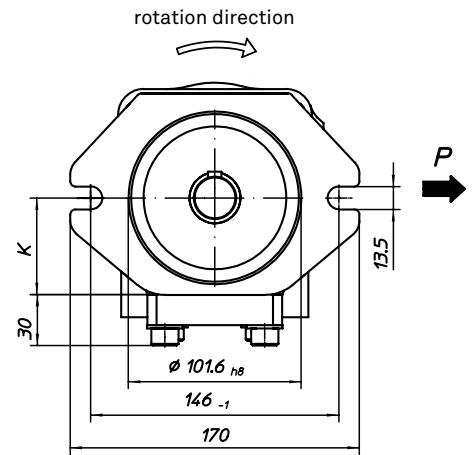
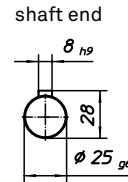
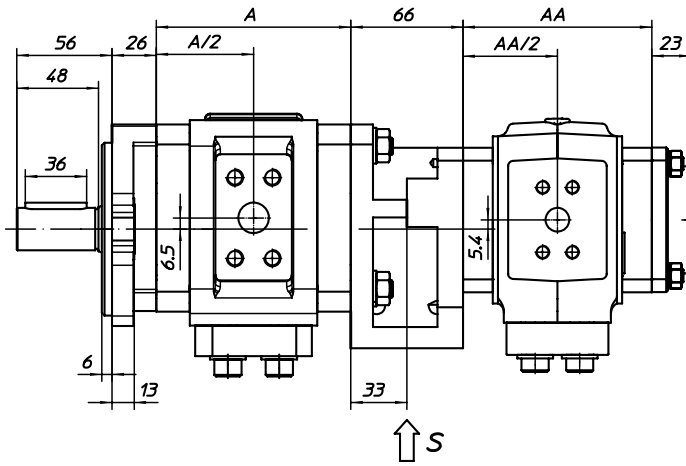

### EIPH3

Size	A	F	G	H	K
014	90,4	64	65	67	57
016	92,4	64	65	67	57
020	97,9	64	65	67	57
025	104,4	64	65	67	57
032	114,4	64	65	67	57
040	125,4	70	73	79	63
050	139,4	70	73	79	63

### EIPH2

Size	AA	FF	GG	HH
004	71	50	55	59
005	71	50	55	59
006	73	50	55	59
008	76	50	55	59
011	82	50	55	59
013	87	50	55	60
016	92	50	55	60
019	99	55	61	65
022	105	55	61	65
025	111	55	61	65

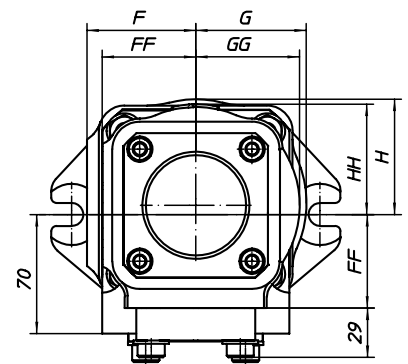

Pressure connections see single pumps

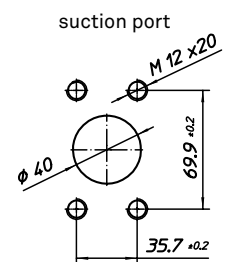

The single pumps of a multiple pump assembly are internally connected, even if you connect to the pump inlet. It is therefore no operating with different fluids possible.



## Pump with SAE-C-2-hole flange and cylindrical shaft

Order example: EIPH5-\_\_\_RA23-1X

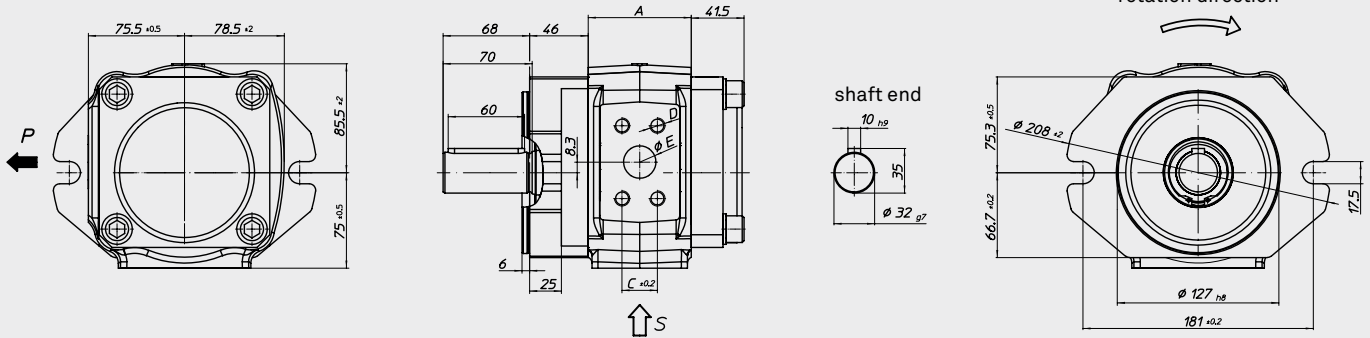

Size	A	B	C	D	E	L	M	N
064	81	57,2*	27,8*	M12x22	25,4	77,8	42,9	51
080	93	66,7*	31,8*	M14x24	31,75	77,8	42,9	51
100	109	66,7*	31,8*	M14x24	31,75	88,9	50,8	63,5

\* Pressure port: SAE 518C, high pressure series (code 62)

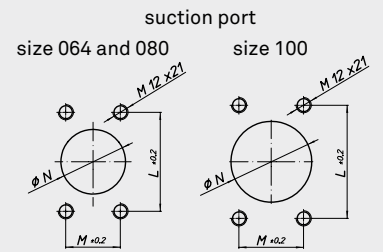

## Double pump with SAE-C-2-hole flange and cylindrical shaft

Order example: EIPH5-\_\_\_SK23-1X+  
EIPH3-\_\_\_RP33-1X

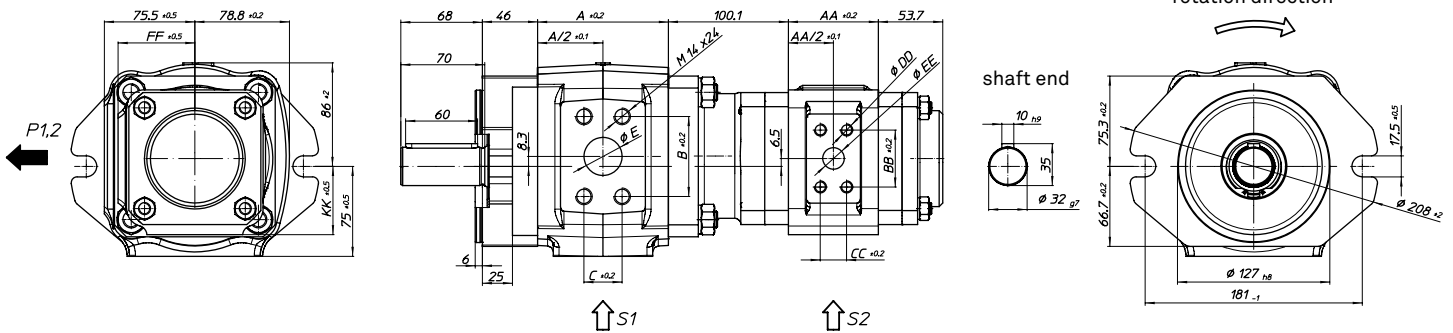

suction port S

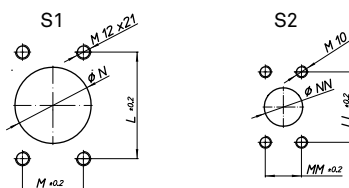

### EIPH5

Size	A	B	C	D	E	L	M	N
064	81	57,2	27,8	M12x22	25,4	77,8	42,9	51
080	93	66,7	31,8	M14x24	31,75	77,8	42,9	51
100	109	66,7	31,8	M14x24	31,75	88,9	50,8	63,5

### EIPH3

Size	AA	BB	CC	DD	EE	FF	KK	LL	MM	NN
014	90,4	38,1	17,5	M8	14	64	57	52,4	26,2	25
016	92,4	38,1	17,5	M8	14	64	57	52,4	26,2	25
020	97,9	47,5	22	M10	18	64	57	58,7	30,2	32
025	104,4	47,5	22	M10	18	64	57	58,7	30,2	32
032	114,4	47,5	22	M10	18	64	57	58,7	30,2	32
040	125,4	52,4	26,2	M10	20	70	63	58,7	30,2	32
050	139,4	52,4	26,2	M10	20	70	63	58,7	30,2	32

## Pump with SAE-C-2-hole flange and splined shaft

Order example: EIPH5-\_\_\_RB23-1X

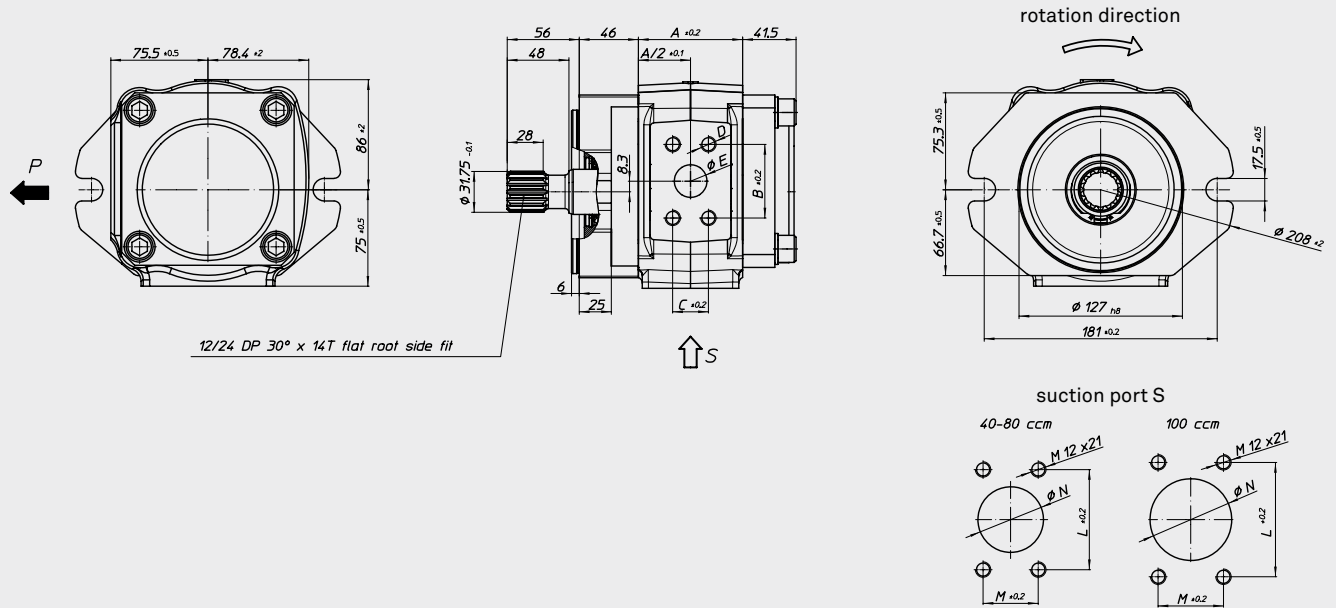

Size	A	B	C	D	E	L	M	N
064	81	57,2*	27,8*	M12x22	25,4	77,8	42,9	51
080	93	66,7*	31,8*	M14x24	31,75	77,8	42,9	51
100	109	66,7*	31,8*	M14x24	31,75	88,9	50,8	63,5

\* Pressure port: SAE 518C, high pressure series (code 62)

## Double pump with SAE-C-2-hole flange and splined shaft

Order example: EIPH5-\_\_\_SL23-1X+  
EIPH3-\_\_\_RE36-1X

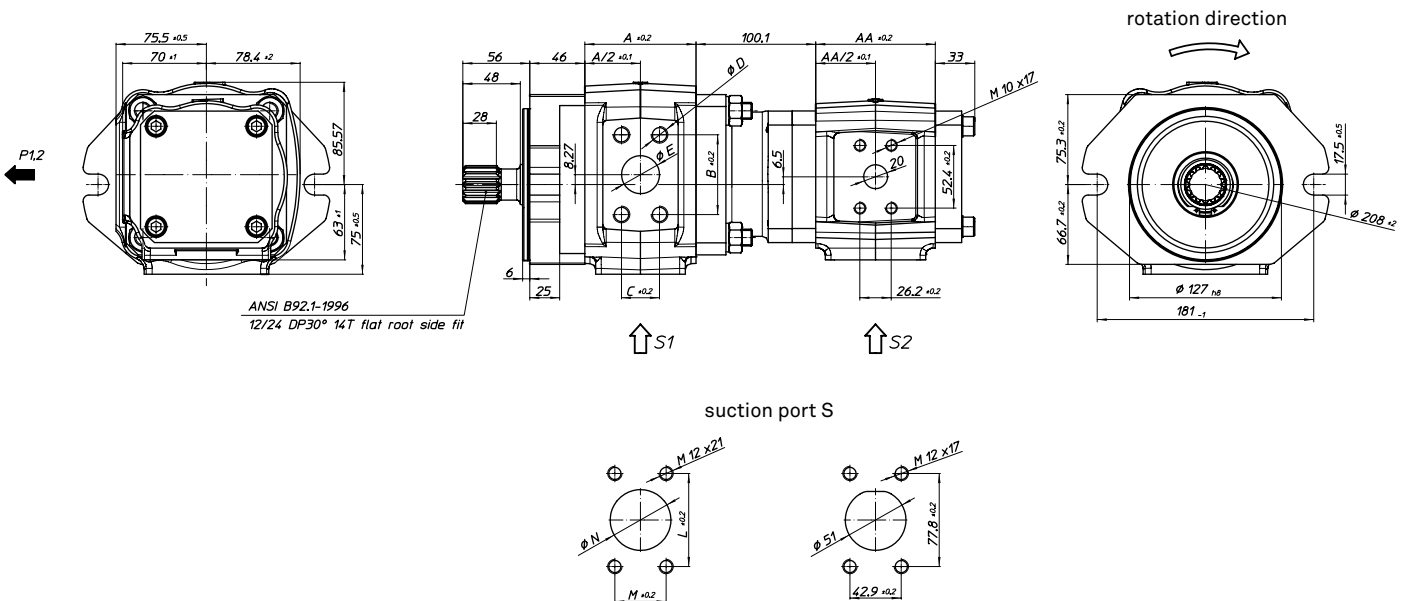

### EIPH5

Size	A	B	C	D	E	L	M	N
064	81	57,2*	27,8*	M12x22	25,4	77,8	42,9	51
080	93	66,7*	31,8*	M14x24	31,75	77,8	42,9	51
100	109	66,7*	31,8*	M14x24	31,75	88,9	50,8	63,5

### EIPH3

NG	AA
040	86
050	100

\* Pressure port: SAE 518C, high pressure series (code 62)

## Pump with SAE-D-2-hole flange and cylindrical shaft

Order example: EIPH6-\_\_\_RK23-1X

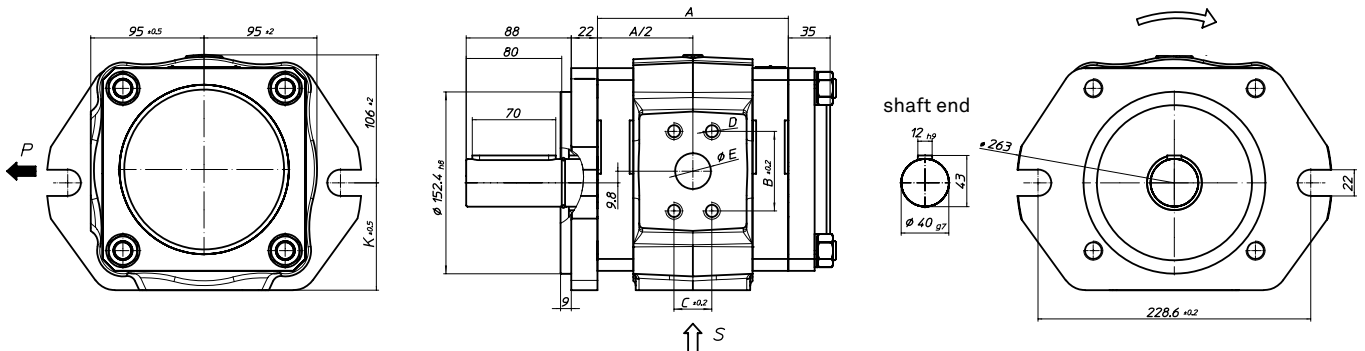

Size	A	B	C	D	E	K	L	M	N	O
040	123	57,2*	27,8*	M12x22	20	90	69,9	35,7	35	M12x25
050	129	57,2*	27,8*	M12x22	20	90	69,9	35,7	40	M12x25
064	138	57,2*	27,8*	M12x22	20	90	69,9	35,7	40	M12x25
080	147	66,7*	31,8*	M14x25	30	90	77,8	42,9	50	M12x25
100	160	66,7*	31,8*	M14x25	30	90	77,8	42,9	50	M12x25
125	175	66,7*	31,8*	M14x25	30	90	77,8	42,9	50	M12x25
160	196	66,7*	31,8*	M14x25	30	90	88,9	50,8	65	M12x25
200	221	79,4*	36,5*	M16x25	38	92	106,4	61,9	76	M16x25
250	251	79,4*	36,5*	M16x25	38	92	106,4	61,9	76	M16x25

\* Pressure port: SAE 518C, high pressure series (code 62)

## Double pump with SAE-D-2-hole flange and cylindrical shaft

Order example: EIPH6-\_\_\_RK20-1X+  
EIPH6-\_\_\_RP30-1X

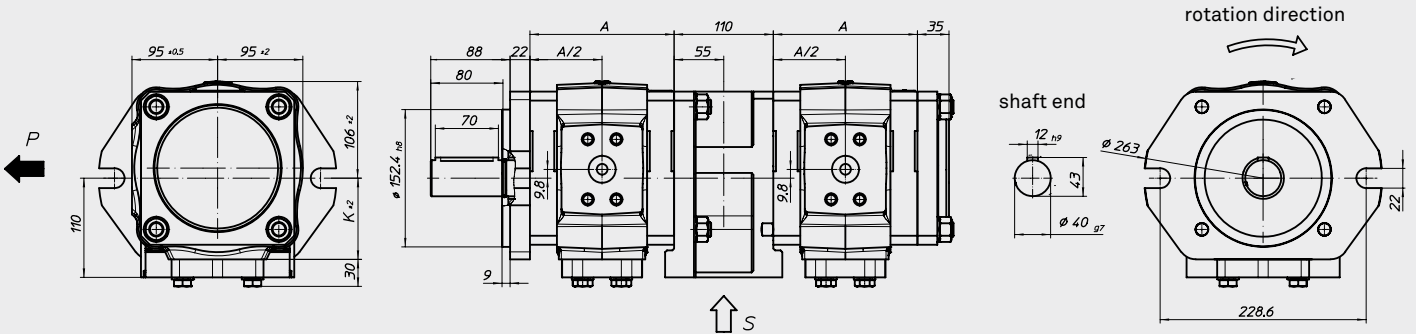

Size	A
040	123
050	129
064	138
080	147
100	160
125	175
160	196
200	221
250	251

Above size 160 no common inlet possible

Pressure connections see single pumps

suction port

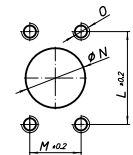

rotation direction



shaft end

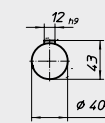

common suction port

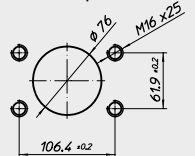

## Double pump with SAE-D-2-hole flange and cylindrical shaft

Order example: EIPH6-\_\_\_RK23-1X+  
EIPH2-\_\_\_RP30-1X

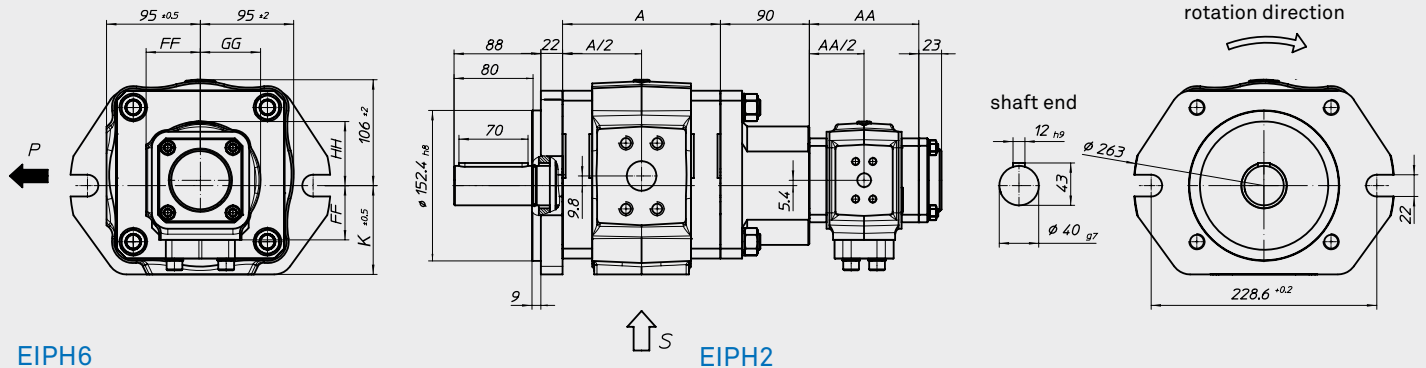

EIPH6

EIPH2

Size	A	K	L	M	N	O
040	123	90	69,9	35,7	35	M12x25
050	129	90	69,9	35,7	40	M12x25
064	138	90	69,9	35,7	40	M12x25
080	147	90	77,8	42,9	50	M12x25
100	160	90	77,8	42,9	50	M12x25
125	175	90	77,8	42,9	50	M12x25
160	196	90	88,9	50,8	65	M12x25
200	221	92	106,4	61,9	76	M16x25
250	251	92	106,4	61,9	76	M16x25

Size	AA	FF	GG	HH
004	71	50	55	59
005	71	50	55	59
006	73	50	55	59
008	76	50	55	59
011	82	50	55	59
013	87	50	55	60
016	92	50	55	60
019	99	55	61	65
022	105	55	61	65
025	111	55	61	65

Pressure connections see single pumps

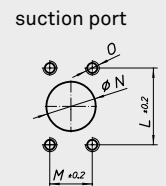

## Double pump with SAE-D-2-hole flange and cylindrical shaft

Order example: EIPH6-\_\_\_RK20-1X+  
EIPH3-\_\_\_RP30-1X

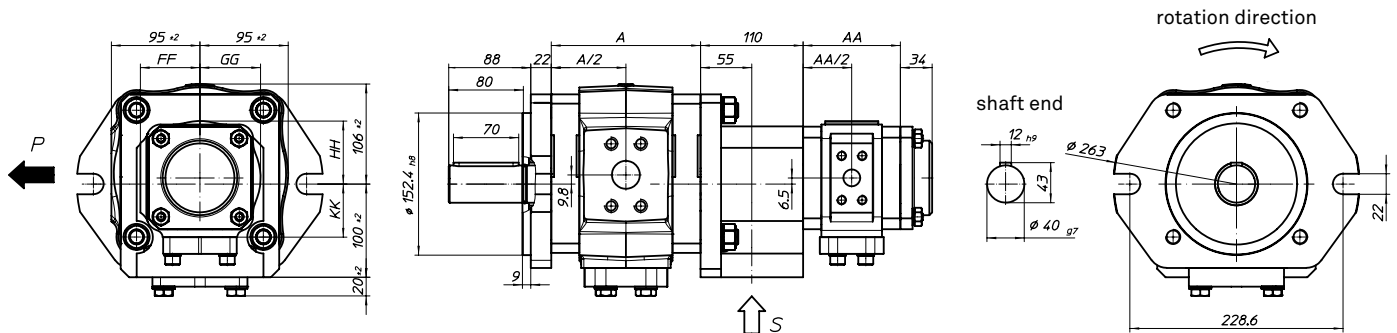

EIPH6

EIPH3

Size	A	Size	AA	FF	GG	HH	KK
040	123	014	90,4	64	65	67	57
050	129	016	92,4	64	65	67	57
064	138	020	97,9	64	65	67	57
080	147	025	104,4	64	65	67	57
100	160	032	114,4	64	65	67	57
125	175	040	125,4	70	73	79	63
160	196	050	139,4	70	73	79	63
200	221						
250	251						

Pressure connections see single pumps  
Above size 160 no common inlet possible

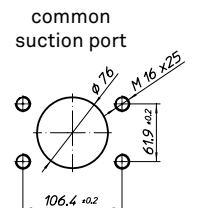

## SAE flange metric tapped

Version a

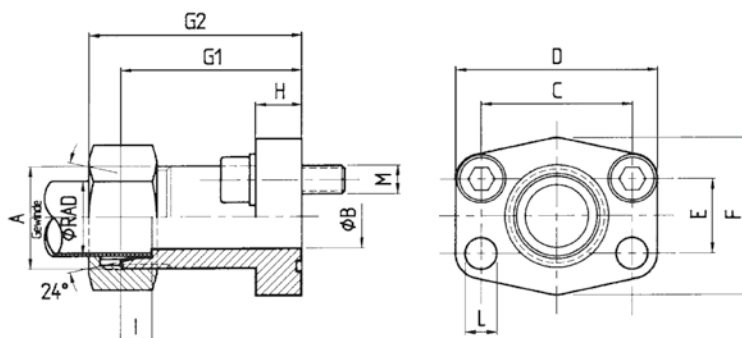

## SAE pipe threaded flange

Version b

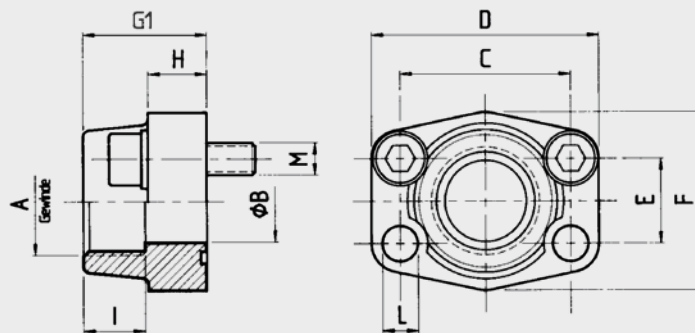

Nr.	Article number	Type	pmax	AD	A	B	C	D	E	F	G1	G2	H	I	L
1a	07 07 04 0030	AD15-SAE12M22x1,5	315	15	M22x1,5	12	38,1	54	17,48	46	52	60	13	7	9
1b	07 07 04 0026	EFG1/2-SAE12	350		G1/2"	13	38,1	54	17,48	46	36		19	19	9
2a	07 07 04 0031	AD22-SAE34M30x2	160	22	M30x2	19	47,63	65	22,23	50	60	69	14	7,5	11,5
2b	07 07 04 0027	EFG3/4-SAE34	350		G3/4"	19	47,63	65	22,23	50	36		18	19	11
3a	07 07 04 0032	AD28-SAE100M36x2	160	28	M36x2	24	52,37	70	26,19	55	63	72	16	7,5	11,5
3b	07 07 04 0028	EFG1-SAE100	315		G1"	25	52,37	70	26,19	55	38		18	22	11
4a	07 07 04 0033	AD35-SAE114M45x2	160	35	M45x2	29	58,72	79	30,18	68	65	76	14	10,5	11,5
4b	07 07 04 0029	EFG1 1/4-SAE114	250		G1 1/4"	32	58,72	79	30,18	68	41		21	22	11,5
5a	07 07 04 0037	AD42-SAE112M52x2	160	42	M52x2	36	69,85	94	35,71	78	70	82	16	11	13,5
5b	07 07 04 0034	EFG1 1/2-SAE112	200		G1 1/2"	38	69,85	94	35,71	78	45		25	24	13,5
6b	07 07 04 0036	EFG2-SAE200	200		G2"	51	77,77	102	42,88	90	45		25	30	13,5
7b	07 07 04 0041	EFG2 1/2-SAE212	160		G2 1/2"	63	88,9	114	50,8	105	50		25	30	13,5
8a	07 07 04 0042	AD30-SAE100M42x2HD	400	30	M42x2	25	57,2	81	27,8	70	82	95	24	13,5	13
9a	07 07 04 0043	AF6-404M/S38M	400	38	M52x2	29	66,6	95	31,8	78	92		27	16	15
10b	07 07 04 0050	EFG3-SAE300-C	160		G3"	73	106,4	134	61,9	116	50		27	38	17,5

## Summary of SAE Pressure- and Suction flange SAE J 518C, ISO 6162

Type	Inlet	Nr.	Version		Outlet	Nr.	Version	
			a	b			a	b
EIPH2-004-005	1/2"	1	•	•	1/2"	1	•	•
EIPH2-006-008	3/4"	2	•	•	1/2"	1	•	•
EIPH2-011-025	1"	3	•	•	1/2"	1	•	•
EIPH2-019-025	1 1/2"	5	•	•	1/2"	1	•	•
EIPH3-014-016	1"	3	•	•	1/2"	1	•	•
EIPH3-020-032	1 1/4"	4	•	•	3/4"	2	•	•
EIPH3-040-064	1 1/4"	4	•	•	1"	3	•	•
EIPH3-040-050	2"	6	•	•	1"	3	•	•
EIPH5-064	2"	6	•	•	1"*	8	•	•
EIPH5-080	2"	6	•	•	1 1/4" *	9	•	•
EIPH5-100	2 1/2"	7	•	•	1 1/4" *	9	•	•
EIPH6-040-064	1 1/2"	5	•	•	1" *	8	•	•
EIPH6-080-125	2"	6	•	•	1 1/4" *	9	•	•
EIPH6-160	2 1/2"	7	•	•	1 1/4" *	9	•	•
EIPH6-200-250	3"	10	•	•	1 1/2" *	9	◦	◦

\* High pressure range

1) For pumps with enlarged suction ports

## Suction flange for Intermediate housing

Type	Inlet	Nr.	Version	
			a	b
EIPH2/2 till size 016	1"	3	•	•
EIPH2/2 from size 019	1 1/4"	4	•	•
EIPH3/2	1 1/2"		•	•
EIPH3/3 till size 032	1 1/2"	5	•	•
EIPH3/3 from size 040	2"	6	•	•
EIPH6/6	3"		◦	◦
EIPH6/3	3"		◦	◦

• = available    ◦ = on request

**EIP H2 - 016 RK03 - 1X SXXX**

**Special version number**

(not applicable with standard pumps or when the type key is unambiguous)

**Revision code**

1st number: Change of mounting dimensions  
2nd number: Change of pump with same mounting dimensions

**Intake and outlet connection**

3: According to SAE J 518  
6: According to SAE J 518 for enlarged suction post for speed controlled drive applications  
0: suction port closed; common inlet  
– other flanges on request –

**Fastening flange**

0: SAE/A 2-hole flange, centring collar Ø 82,55  
2: SAE/B 2-hole flange, centring collar Ø 101,6  
2: SAE/C 2-hole flange, centring collar Ø 127,0 at EIPH5  
2: SAE/D 2-hole flange, centring collar Ø 152,4 at EIPH6  
3: Direct fixture  
5: VDMA on request  
– other flanges on request –

**Shaft end**

A: Cylindrical  
K: Cylindrical with spigot  
B: SAE gear  
L: SAE gear with spigot  
E: Spigot tooth system on one side  
P: Spigot tooth system on both sides

**Rotation direction**

R: Clockwise  
L: Anticlockwise

**Rated size**

Three digits

**Overall size**

2, 3, 5 or 6

**Type**

H: High pressure pump

**Eckerle internal gear pump**

**Order example**

**EIPH2-016RK03-1X**

High pressure pump, overall size 2 with 15,8 cm<sup>3</sup>/U, clockwise rotation, cylindrical shaft with cone, SAE/B-2-hole flange connection, SAE flange connection, revision code 1X

## Variable-speed operation

As a matter of principle, Eckerle internal gear pumps are eminently suited for variable speed operation. Even at low viscosities and high temperatures of the pumping medium, the pumps run extremely energy efficiently and highly dynamically over a wide speed range due to the radial and axial gap compensation.

However, with variable speed operation certain boundary conditions should be observed. The exemplary cycle shown below illustrates this clearly.

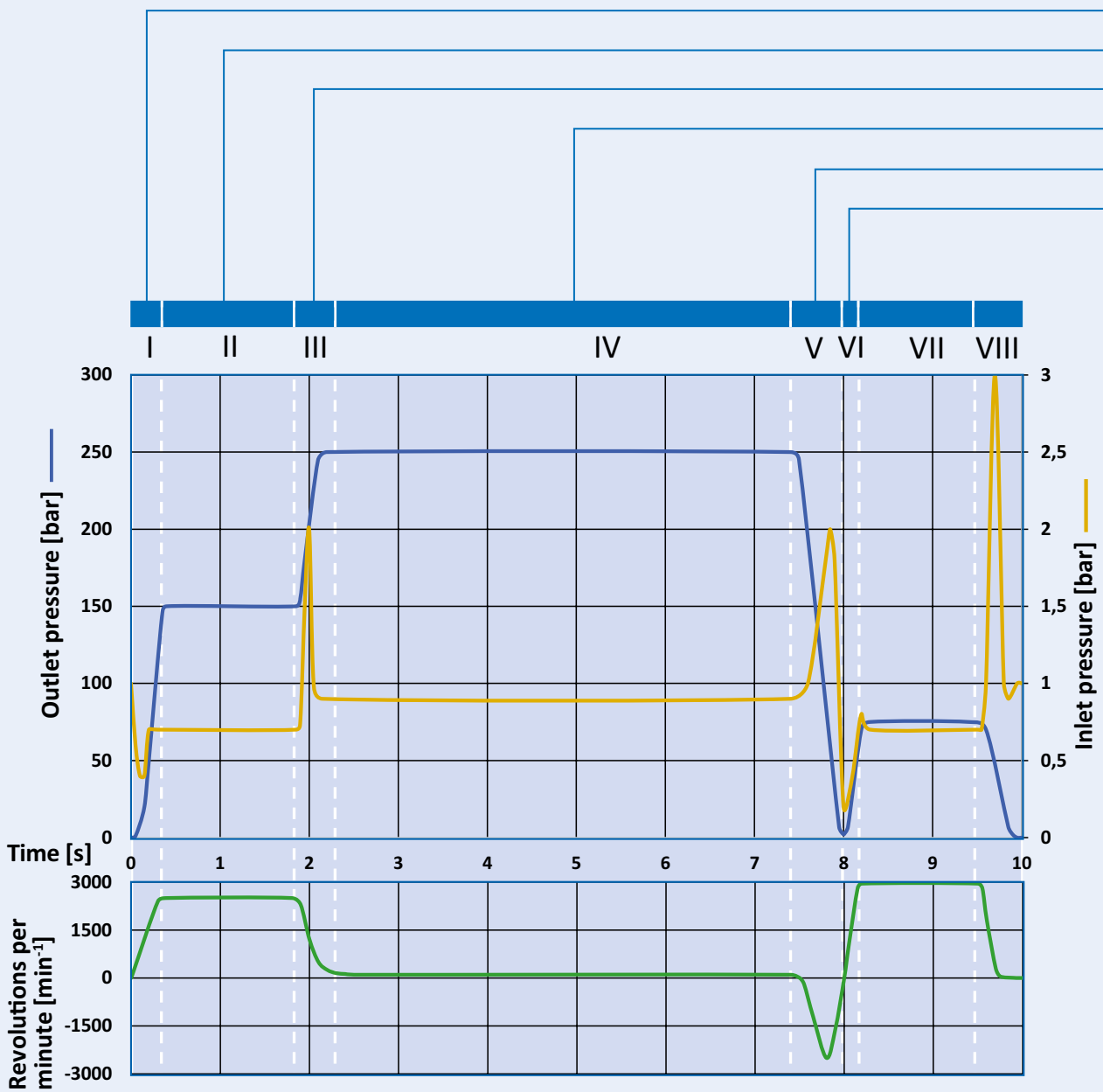



#### **I. Start:**

Eckerle internal gear pumps are able to build up pressure from standstill. This happens smoothly when the pump starts from an unpressurized state. Please talk to Eckerle, if due to the system design the pump is pressurized at standstill.

#### **II. Pump operation:**

Eckerle internal gear pumps are capable of providing a speed-dependent volumetric flow at any pressure level during pump operation. However, application limits of the respective sizes must be observed.<sup>2)</sup>

#### **III. Deceleration:**

With Eckerle internal gear pumps very high decelerations can be achieved. It must be ensured though that line-dependent pressure peaks can develop within the suction side. These should not exceed the maximum permissible inlet pressure.<sup>2) 3)</sup>

#### **IV. Pressure Holding Operation:**

Eckerle internal gear pumps are able to build up high pressures even at very low speeds due to the gap compensation. Hold pressure operation is thus extremely energy-efficient. Pump operation should follow after the hold pressure operation to flush out the pump.

#### **V. Reverse operation:**

Eckerle internal gear pumps are usually able to run highly dynamically in the opposite direction of rotation in order to lower pressure peaks, or by means of a hydraulic motor. However, it must be ensured that the output pressure is always higher than the input pressure.<sup>1) 3)</sup>

#### **VI. Acceleration:**

With Eckerle internal gear pumps very large speed-ups can be run. These are limited by inlet pressure, geometry of the suction line and viscosity. However, these may not drop below the specified minimum inlet pressure of the series.<sup>1) 3)</sup>

1) See Characteristics

2) See Technical data

3) To avoid critical operating points, we recommend taking measurements of the pump's inlet and outlet pressure near the pump with a scanning rate of at least 1 kHz when a new pump cycle starts.

## Volume flow

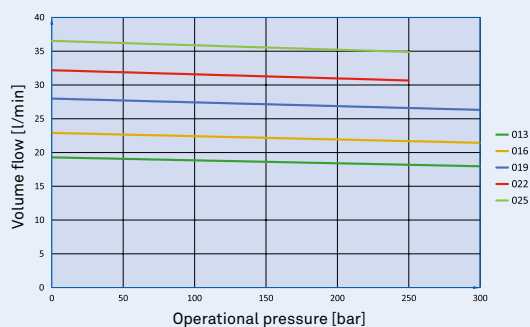
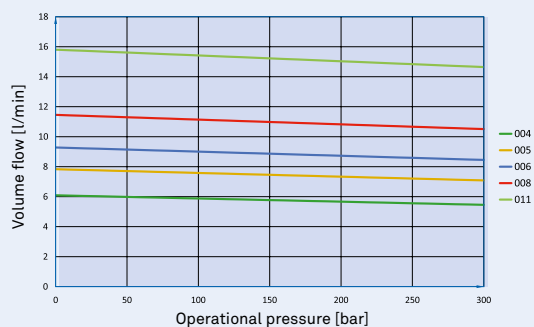

## Level of efficiency

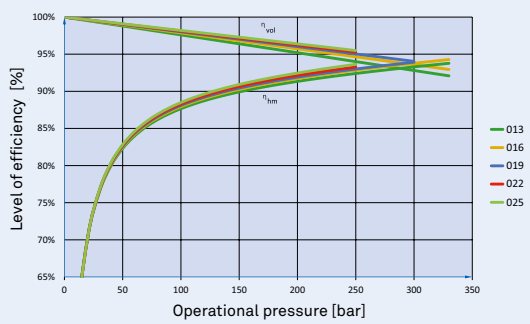
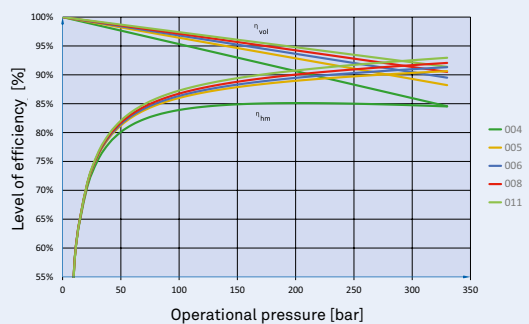

## Driving power

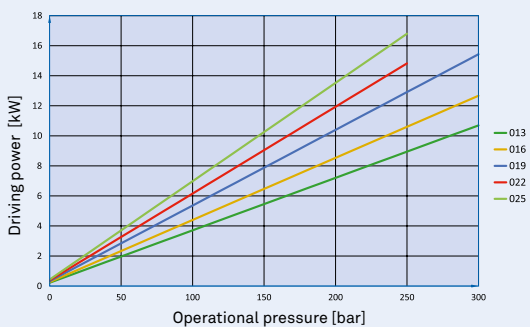
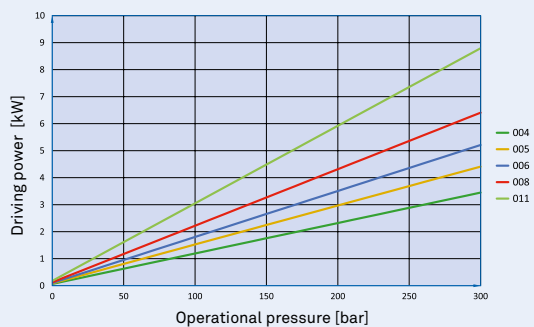

## Sound level pressure in air

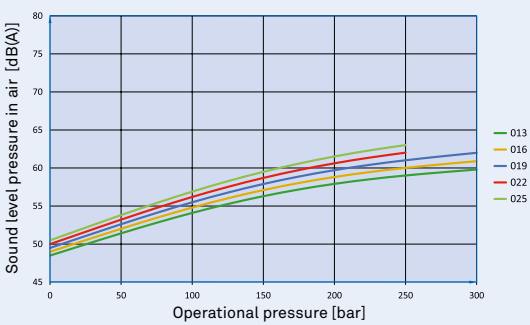
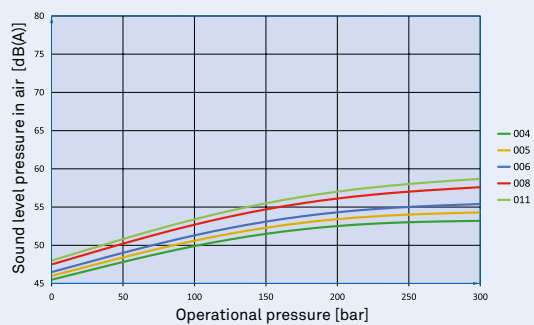

Measurement conditions: Speed 1450 min<sup>-1</sup>, viscosity 46 mm<sup>2</sup>/s, operating temperature 40°C  
 Measured in silent room in accordance with DIN 45 635 sheet 26, microphone distance: 1 m axial

## Volume flow

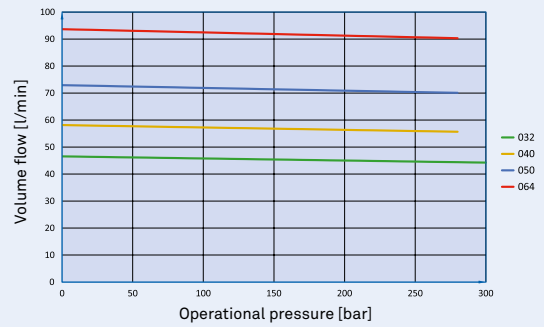
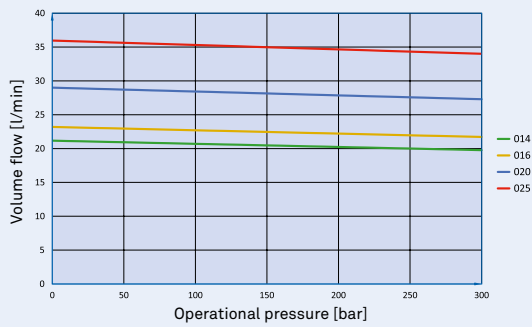

## Level of efficiency

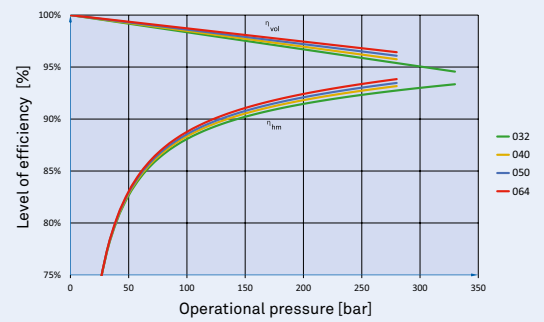
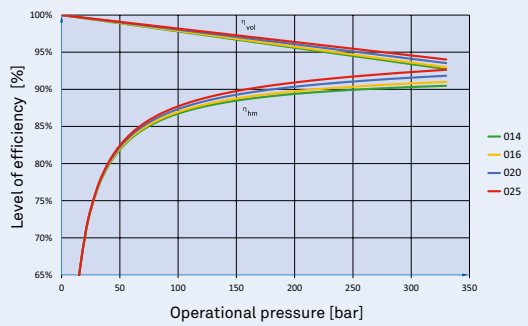

## Driving power

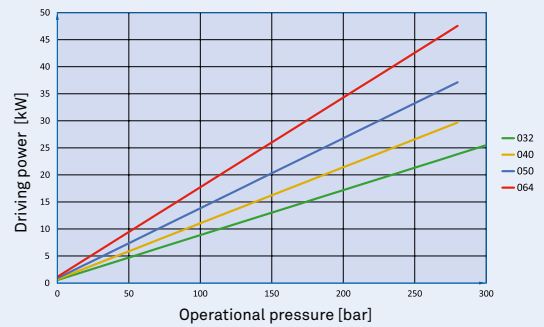
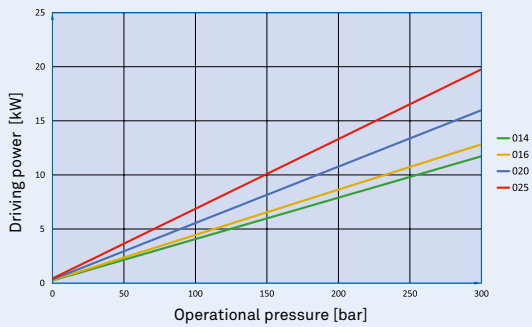

## Sound level pressure in air

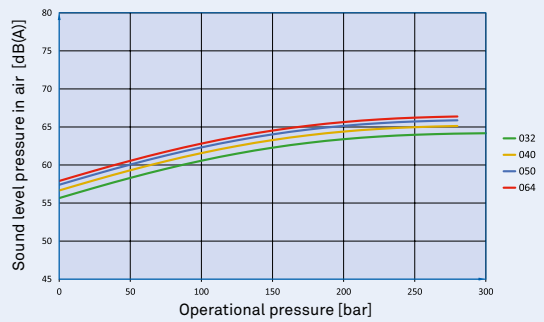
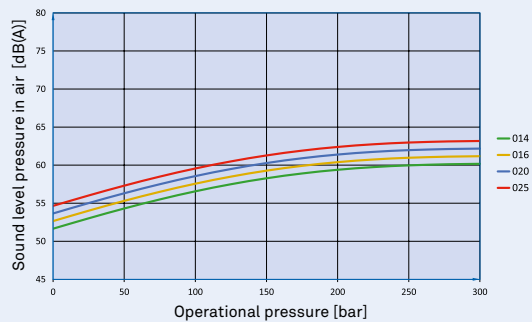

Measurement conditions: Speed 1450 min<sup>-1</sup>, viscosity 46 mm<sup>2</sup>/s, operating temperature 40°C  
 Measured in silent room in accordance with DIN 45 635 sheet 26, microphone distance: 1 m axial

## Volume flow

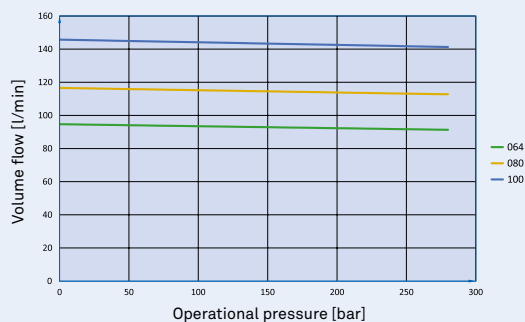

## Level of efficiency

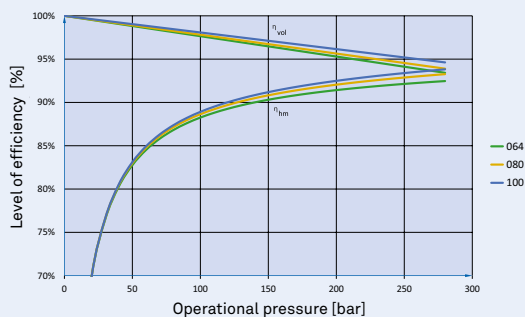

## Driving power

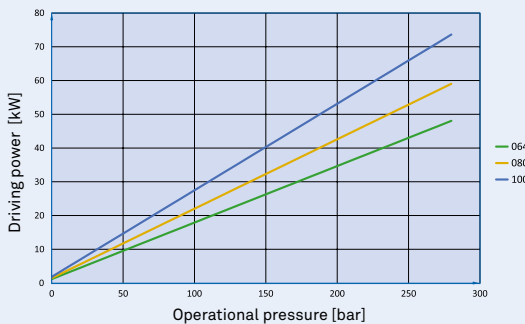

## Sound level pressure in air

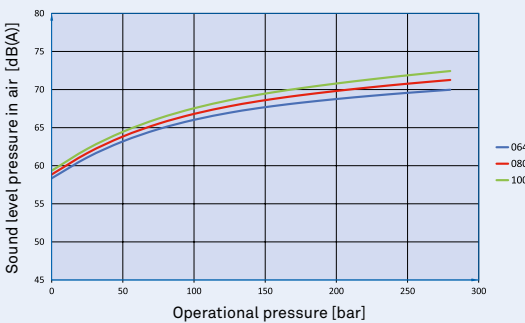

Measurement conditions: Speed 1450 min<sup>-1</sup>, viscosity 46 mm<sup>2</sup>/s, operating temperature 40°C  
 Measured in silent room in accordance with DIN 45 635 sheet 26, microphone distance: 1 m axial

## Volume flow

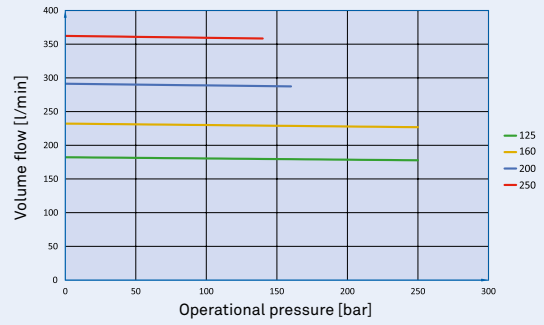
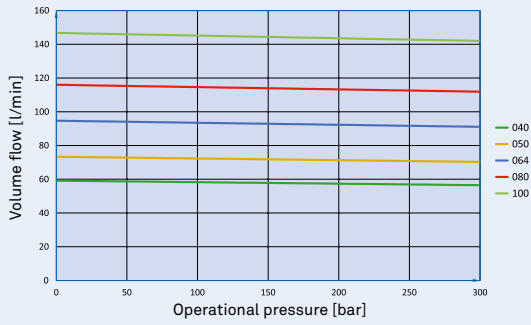

## Level of efficiency

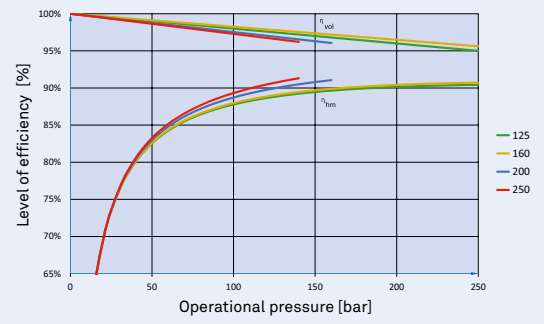
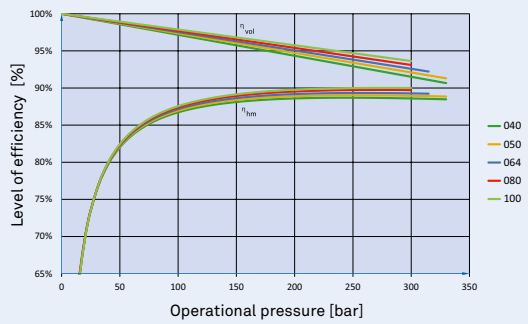

## Driving power

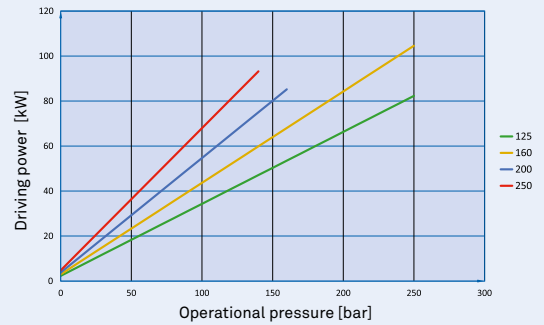
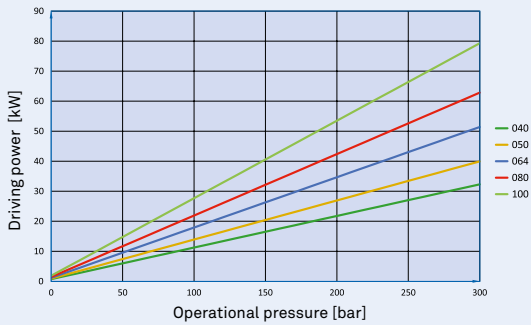

## Sound level pressure in air

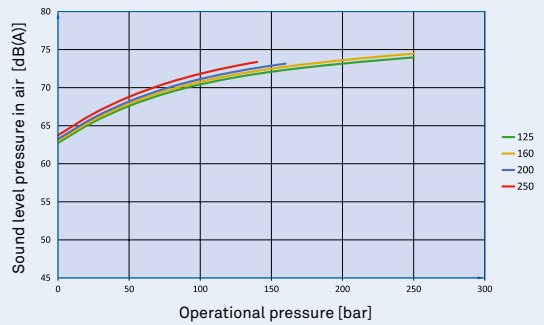
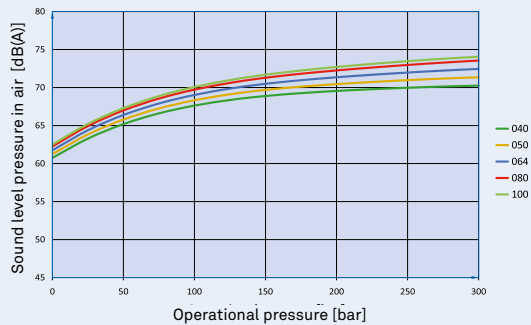

Measurement conditions: Speed 1450 min<sup>-1</sup>, viscosity 46 mm<sup>2</sup>/s, operating temperature 40°C  
 Measured in silent room in accordance with DIN 45 635 sheet 26, microphone distance: 1 m axial

# Characteristics

## Permissible peak operational pressure dependent on speed

EIPH2

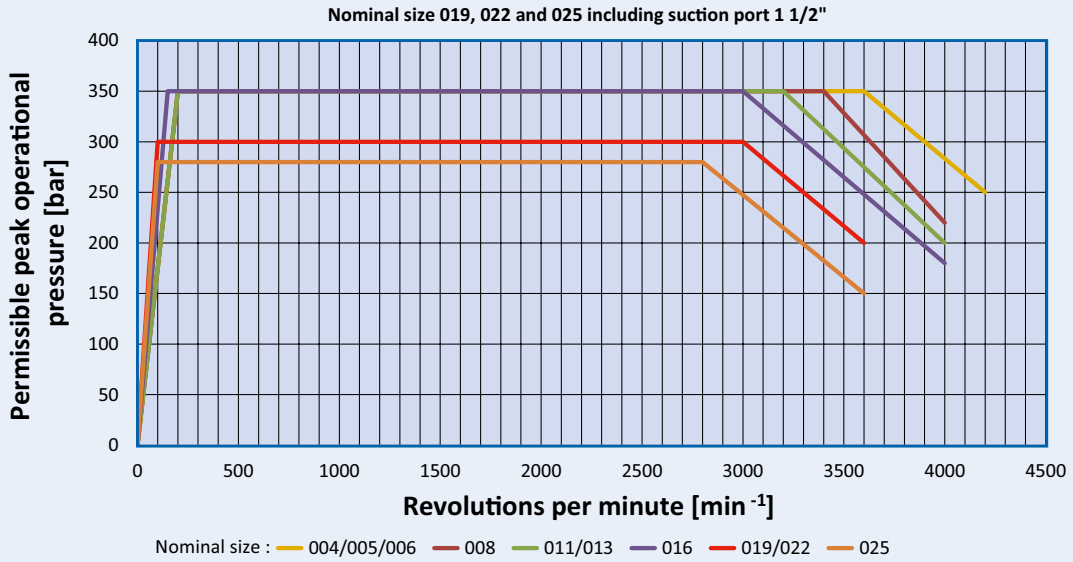

EIPH3

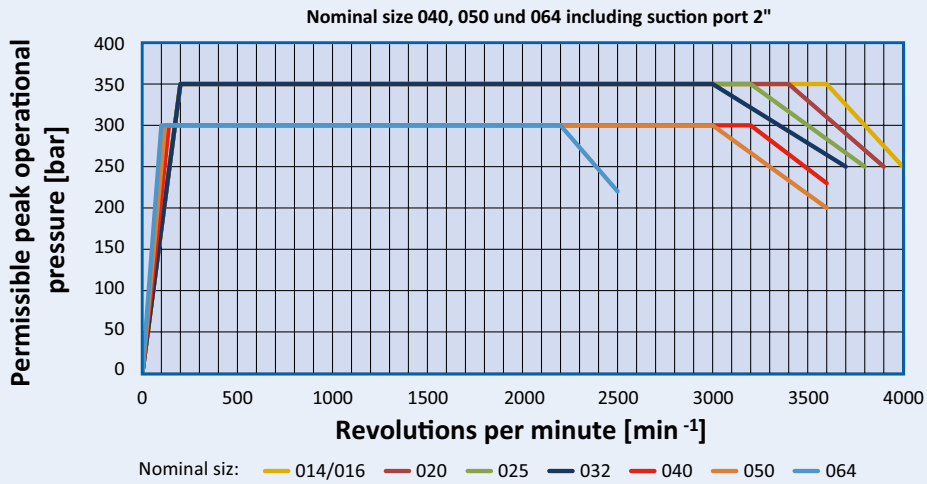

Peak operating pressures are permitted for a maximum of 10 seconds or 15% of the duty cycle

EIPH5

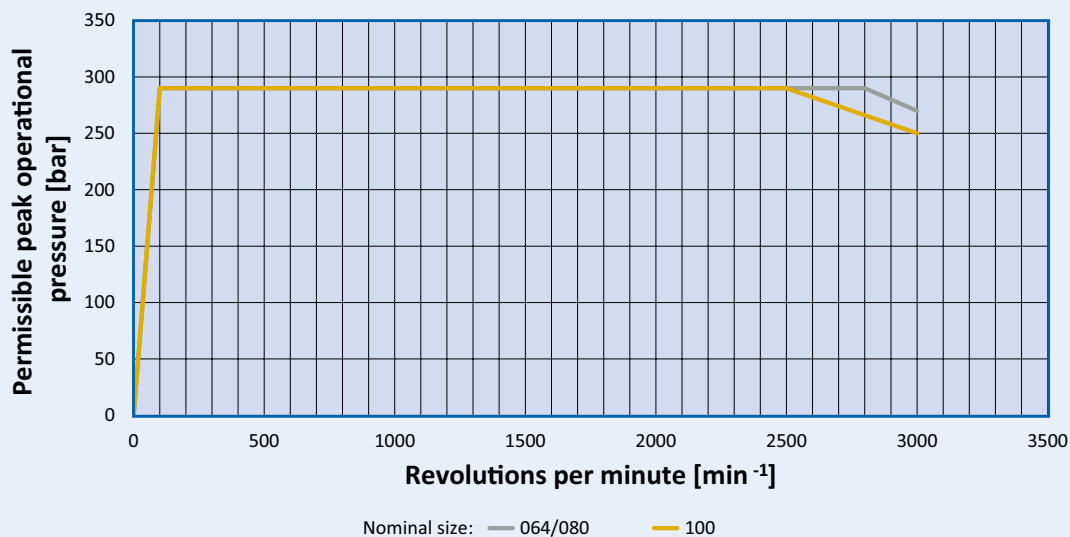

EIPH6

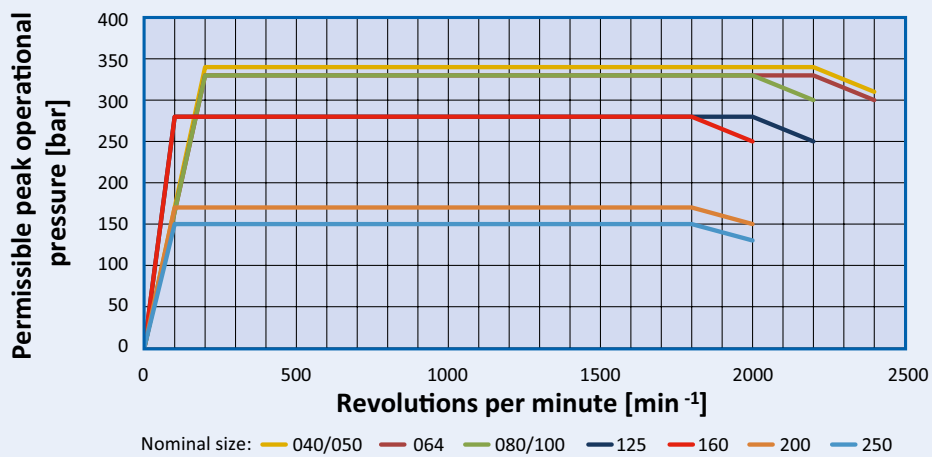



**For further information please visit:  
eckerle.com**

All indicated data serve alone the product description and are not as characteristics in the legal sense to be understood. Subject to alterations.

Eckerle Industrie-Elektronik GmbH · P.O. box 1368  
Otto-Eckerle-Straße 6/12A  
D-76316 Malsch, Germany  
Phone: +49 (0) 7246 9204-0  
sales.EHD@eckerle.com · www.eckerle.com

**eckerle**